

# Low $I_Q$ , Dual, 2-Phase Synchronous Step-Down Controller

## FEATURES

- Low Operating  $I_Q$ : 50 $\mu$ A (One Channel On)
- Wide Output Voltage Range:  $0.8V \leq V_{OUT} \leq 24V$
- Wide  $V_{IN}$  Range: 4V to 38V
- $R_{SENSE}$  or DCR Current Sensing
- Out-of-Phase Controllers Reduce Required Input Capacitance and Power Supply Induced Noise
- OPTI-LOOP<sup>®</sup> Compensation Minimizes  $C_{OUT}$
- Phase-Lockable Frequency (75kHz-850kHz)
- Programmable Fixed Frequency (50kHz-900kHz)
- Selectable Continuous, Pulse-Skipping or Low Ripple Burst Mode<sup>®</sup> Operation at Light Loads
- Very Low Dropout Operation: 99% Duty Cycle
- Adjustable Output Voltage Soft-Start or Tracking
- Power Good Output Voltage Monitor
- Output Overvoltage Protection
- Low Shutdown  $I_Q$ : <8 $\mu$ A
- Internal LDO Powers Gate Drive from  $V_{IN}$  or  $EXTV_{CC}$
- No Current Foldback During Start-Up
- Narrow SSOP Package

## APPLICATIONS

- Automotive Always-On Systems
- Battery Operated Digital Devices
- Distributed DC Power Systems

## DESCRIPTION

The LTC<sup>®</sup>3857-1 is a high performance dual step-down switching regulator controller that drives all N-channel synchronous power MOSFET stages. A constant frequency current mode architecture allows a phase-lockable frequency of up to 850kHz. Power loss and noise due to the ESR of the input capacitor ESR are minimized by operating the two controller output stages out of phase.

The 50 $\mu$ A no-load quiescent current extends operating life in battery-powered systems. The LTC3857-1 features a precision 0.8V reference and a power good output indicator. A wide 4V to 38V input supply range encompasses a wide range of intermediate bus voltages and battery chemistries.

Independent TRACK/SS pins for each controller ramp the output voltages during start-up. Current foldback limits MOSFET heat dissipation during short-circuit conditions. The PLLIN/MODE pin selects among Burst Mode operation, pulse-skipping mode, or continuous inductor current mode at light loads.

For a leadless 32-pin QFN package with the additional features of adjustable current limit, clock out, phase modulation and two PGOOD outputs, see the LTC3857 data sheet.

LT, LTC, LTM, Burst Mode, OPTI-LOOP  $\mu$ Module, Linear Technology and the Linear logo are registered trademarks and No  $R_{SENSE}$  and UltraFast are trademarks of Linear Technology Corporation. All other trademarks are the property of their respective owners. Protected by U.S. Patents, including 5481178, 5929620, 6177787, 6144194, 5408150, 6580258, 5705919, 6100678.

## TYPICAL APPLICATION

High Efficiency Dual 3.3V/8.5V Step-Down Converter

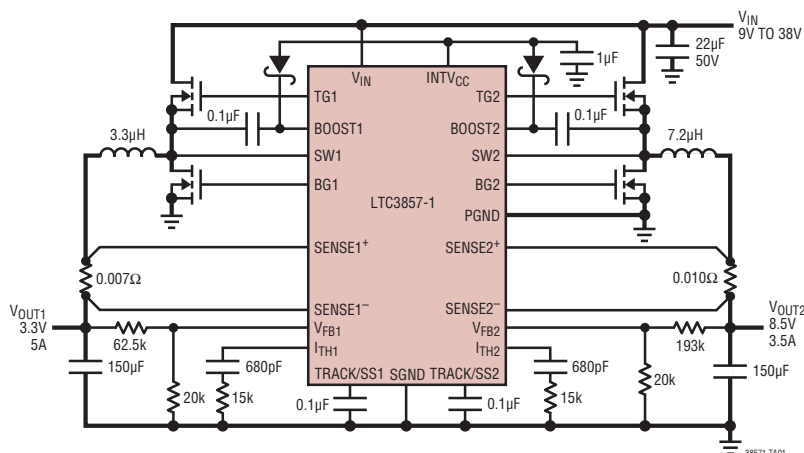

Efficiency and Power Loss vs Output Current

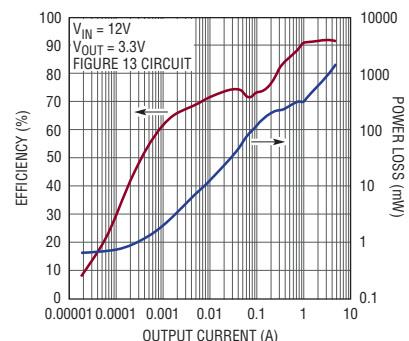



**ELECTRICAL CHARACTERISTICS** The ● denotes the specifications which apply over the full operating junction temperature range, otherwise specifications are at  $T_A = 25^\circ\text{C}$  (Note 2).  $V_{IN} = 12\text{V}$ ,  $V_{RUN1,2} = 5\text{V}$ ,  $EXTV_{CC} = 0\text{V}$  unless otherwise noted.

SYMBOL	PARAMETER	CONDITIONS	MIN	TYP	MAX	UNITS	
$V_{IN}$	Input Supply Operating Voltage Range		4		38	V	
$V_{FB1,2}$	Regulated Feedback Voltage	(Note 4) $I_{TH1,2}$ Voltage = 1.2V –40°C to 125°C –40°C to 85°C	● 0.788 0.792	0.800 0.800	0.812 0.808	V V	
$I_{FB1,2}$	Feedback Current	(Note 4)		±5	±50	nA	
$V_{REFLNREG}$	Reference Voltage Line Regulation	(Note 4) $V_{IN} = 4.5\text{V}$ to 38V		0.002	0.02	%/V	
$V_{LOADREG}$	Output Voltage Load Regulation	(Note 4) Measured in Servo Loop, $\Delta I_{TH}$ Voltage = 1.2V to 0.7V	●	0.01	0.1	%	
		(Note 4) Measured in Servo Loop, $\Delta I_{TH}$ Voltage = 1.2V to 2V	●	–0.01	–0.1	%	
$g_{m1,2}$	Transconductance Amplifier $g_m$	(Note 4) $I_{TH1,2} = 1.2\text{V}$ , Sink/Source = 5 $\mu\text{A}$		2		mmho	
$I_Q$	Input DC Supply Current	(Note 5)					
	Pulse-Skipping or Forced Continuous Mode (One Channel On)	RUN1 = 5V and RUN2 = 0V, $V_{FB1} = 0.83\text{V}$ (No Load) or RUN1 = 0V and RUN2 = 5V, $V_{FB2} = 0.83\text{V}$ (No Load)		2		mA	
	Pulse-Skipping or Forced Continuous Mode (Both Channels On)	RUN1,2 = 5V, $V_{FB1,2} = 0.83\text{V}$ (No Load)		2		mA	
	Sleep Mode (One Channel On)	RUN1 = 5V and RUN2 = 0V, $V_{FB1} = 0.83\text{V}$ (No Load) or RUN1 = 0V and RUN2 = 5V, $V_{FB2} = 0.83\text{V}$ (No Load)		50	75	$\mu\text{A}$	
	Sleep Mode (Both Channels On)	RUN1,2 = 5V, $V_{FB1,2} = 0.83\text{V}$ (No Load)		65	120	$\mu\text{A}$	
	Shutdown	RUN1,2 = 0V		8	20	$\mu\text{A}$	
UVLO	Undervoltage Lockout	INTV <sub>CC</sub> Ramping Up INTV <sub>CC</sub> Ramping Down	● 3.6 ●	4.0 3.8	4.2 4	V V	
$V_{OVL}$	Feedback Overvoltage Protection	Measured at $V_{FB1,2}$ , Relative to Regulated $V_{FB1,2}$		7	10	13	%
$I_{SENSE^+}$	SENSE <sup>+</sup> Pin Current	Each Channel			±1	$\mu\text{A}$	
$I_{SENSE^-}$	SENSE <sup>-</sup> Pins Current	Each Channel $V_{SENSE^-} < INTV_{CC} - 0.5\text{V}$ $V_{SENSE^-} > INTV_{CC} + 0.5\text{V}$		550	±1	$\mu\text{A}$ $\mu\text{A}$	
$DF_{MAX}$	Maximum Duty Factor	In Dropout, $FREQ = 0\text{V}$		98	99.4	%	
$I_{TRACK/SS1,2}$	Soft-Start Charge Current	$V_{TRACK1,2} = 0\text{V}$		0.7	1.0	1.4	$\mu\text{A}$
$V_{RUN1,2 On}$	RUN Pin On Threshold	$V_{RUN1}$ , $V_{RUN2}$ Rising	●	1.21	1.26	1.31	V
$V_{RUN1,2 Hyst}$	RUN Pin Hysteresis			50		mV	
$V_{SENSE(MAX)}$	Maximum Current Sense Threshold	$V_{FB1,2} = 0.7\text{V}$ , $V_{SENSE1^-2^-} = 3.3\text{V}$	●	43	50	57	mV

#### Gate Driver

$TG_{1,2}$	Pull-Up On-Resistance Pull-Down On-Resistance			2.5 1.5		$\Omega$ $\Omega$
$BG_{1,2}$	Pull-Up On-Resistance Pull-Down On-Resistance			2.4 1.1		$\Omega$ $\Omega$
$TG_{1,2} t_r$ $TG_{1,2} t_f$	TG Transition Time: Rise Time Fall Time	(Note 6) $C_{LOAD} = 3300\text{pF}$ $C_{LOAD} = 3300\text{pF}$		25 16		ns ns
$BG_{1,2} t_r$ $BG_{1,2} t_f$	BG Transition Time: Rise Time Fall Time	(Note 6) $C_{LOAD} = 3300\text{pF}$ $C_{LOAD} = 3300\text{pF}$		28 13		ns ns

## ELECTRICAL CHARACTERISTICS

The ● denotes the specifications which apply over the full operating junction temperature range, otherwise specifications are at  $T_A = 25^\circ\text{C}$  (Note 2).  $V_{IN} = 12\text{V}$ ,  $V_{RUN1,2} = 5\text{V}$ ,  $\text{EXTV}_{CC} = 0\text{V}$  unless otherwise noted.

SYMBOL	PARAMETER	CONDITIONS	MIN	TYP	MAX	UNITS
TG/BG $t_{1D}$	Top Gate Off to Bottom Gate On Delay Synchronous Switch-On Delay Time	$C_{LOAD} = 3300\text{pF}$ Each Driver		30		ns
BG/TG $t_{1D}$	Bottom Gate Off to Top Gate On Delay Top Switch-On Delay Time	$C_{LOAD} = 3300\text{pF}$ Each Driver		30		ns
$t_{ON(MIN)}$	Minimum On-Time	(Note 7)		95		ns
<b>INTV<sub>CC</sub> Linear Regulator</b>						
$V_{INTV_{CC}VIN}$	Internal $V_{CC}$ Voltage	$6\text{V} < V_{IN} < 38\text{V}$ , $V_{EXTV_{CC}} = 0\text{V}$	4.85	5.1	5.35	V
$V_{LDOVIN}$	INTV <sub>CC</sub> Load Regulation	$I_{CC} = 0\text{mA}$ to $50\text{mA}$ , $V_{EXTV_{CC}} = 0\text{V}$		0.7	1.1	%
$V_{INTV_{CC}EXT}$	Internal $V_{CC}$ Voltage	$6\text{V} < V_{EXTV_{CC}} < 13\text{V}$	4.85	5.1	5.35	V
$V_{LDOEXT}$	INTV <sub>CC</sub> Load Regulation	$I_{CC} = 0\text{mA}$ to $50\text{mA}$ , $V_{EXTV_{CC}} = 8.5\text{V}$		0.6	1.1	%
$V_{EXTV_{CC}}$	EXTV <sub>CC</sub> Switchover Voltage	EXTV <sub>CC</sub> Ramping Positive	4.5	4.7	4.9	V
$V_{LDOHYS}$	EXTV <sub>CC</sub> Hysteresis			250		mV
<b>Oscillator and Phase-Locked Loop</b>						
$f_{25k\Omega}$	Programmable Frequency	$R_{FREQ} = 25\text{k}$ , PLLIN/MODE = DC Voltage		105		kHz
$f_{65k\Omega}$	Programmable Frequency	$R_{FREQ} = 65\text{k}$ , PLLIN/MODE = DC Voltage	375	440	505	kHz
$f_{105k\Omega}$	Programmable Frequency	$R_{FREQ} = 105\text{k}$ , PLLIN/MODE = DC Voltage		835		kHz
$f_{LOW}$	Low Fixed Frequency	$V_{FREQ} = 0\text{V}$ , PLLIN/MODE = DC Voltage	320	350	380	kHz
$f_{HIGH}$	High Fixed Frequency	$V_{FREQ} = \text{INTV}_{CC}$ , PLLIN/MODE = DC Voltage	485	535	585	kHz
$f_{SYNC}$	Synchronizable Frequency	PLLIN/MODE = External Clock	● 75		850	kHz
<b>PGOOD1 Output</b>						
$V_{PGL}$	PGOOD1 Voltage Low	$I_{PGOOD} = 2\text{mA}$		0.2	0.4	V
$I_{PGOOD}$	PGOOD1 Leakage Current	$V_{PGOOD} = 5\text{V}$			$\pm 1$	$\mu\text{A}$
$V_{PG}$	PGOOD1 Trip Level	$V_{FB1}$ with Respect to Set Regulated Voltage $V_{FB1}$ Ramping Negative Hysteresis	-13	-10 2.5	-7	% %
		$V_{FB1}$ with Respect to Set Regulated Voltage $V_{FB1}$ Ramping Positive Hysteresis	7	10 2.5	13	% %
$t_{PG}$	Delay for Reporting a Fault			25		$\mu\text{s}$

**Note 1:** Stresses beyond those listed under Absolute Maximum Ratings may cause permanent damage to the device. Exposure to any Absolute Maximum Ratings for extended periods may affect device reliability and lifetime.

**Note 2:** The LTC3857-1 is tested under pulsed conditions such that  $T_J \approx T_A$ . The LTC3857E-1 is guaranteed to meet performance specifications from  $0^\circ\text{C}$  to  $85^\circ\text{C}$ . Specifications over the  $-40^\circ\text{C}$  to  $125^\circ\text{C}$  operating junction temperature range are assured by design, characterization and correlation with statistical process controls. The LTC3857I-1 is guaranteed over the full  $-40^\circ\text{C}$  to  $125^\circ\text{C}$  operating junction temperature range. Note that the maximum ambient temperature is determined by specific operating conditions in conjunction with board layout, the rated package thermal resistance and other environmental factors.

**Note 3:**  $T_J$  is calculated from the ambient temperature  $T_A$  and power dissipation  $P_D$  according to the following formula:

$$T_J = T_A + (P_D \cdot 90^\circ\text{C/W})$$

**Note 4:** The LTC3857-1 is tested in a feedback loop that serves  $V_{ITH1,2}$  to a specified voltage and measures the resultant  $V_{FB1,2}$ . The specification at  $85^\circ\text{C}$  is not tested in production. This specification is assured by design, characterization and correlation to production testing at  $125^\circ\text{C}$ .

**Note 5:** Dynamic supply current is higher due to the gate charge being delivered at the switching frequency. See Applications information.

**Note 6:** Rise and fall times are measured using 10% and 90% levels. Delay times are measured using 50% levels.

**Note 7:** The minimum on-time condition is specified for an inductor peak-to-peak ripple current  $\geq 40\%$  of  $I_{MAX}$  (See Minimum On-Time Considerations in the Applications Information section).

# TYPICAL PERFORMANCE CHARACTERISTICS

**Efficiency and Power Loss vs Output Current**

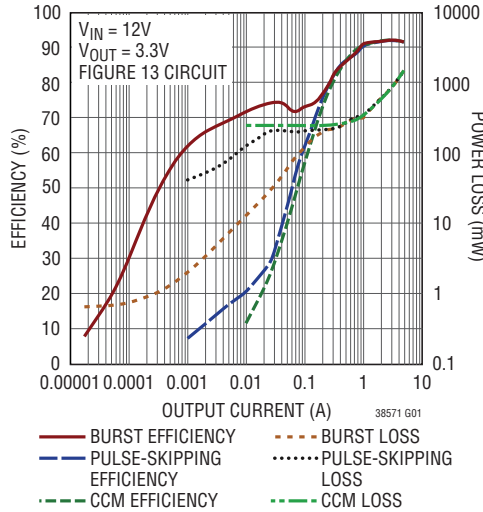

**Efficiency vs Output Current**

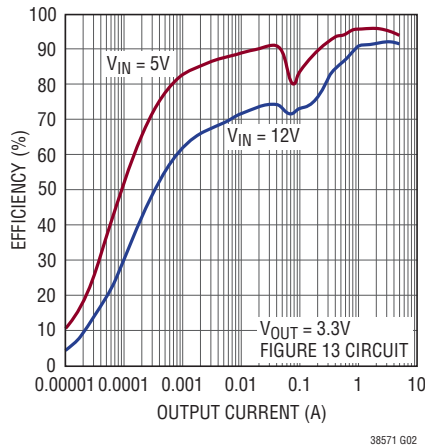

**Efficiency vs Input Voltage**

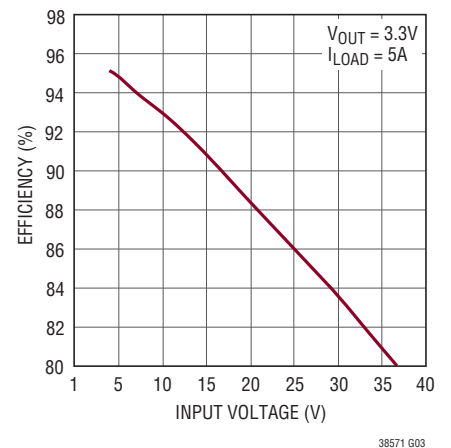

**Load Step (Burst Mode Operation)**

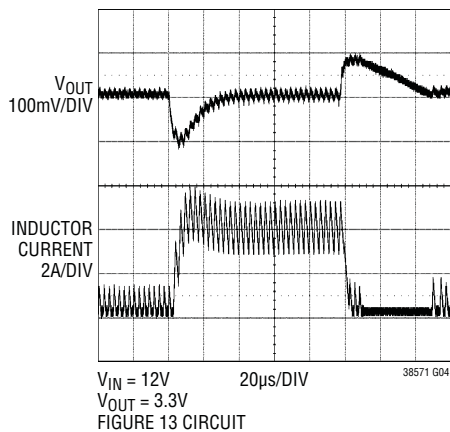

**Load Step (Forced Continuous Mode)**

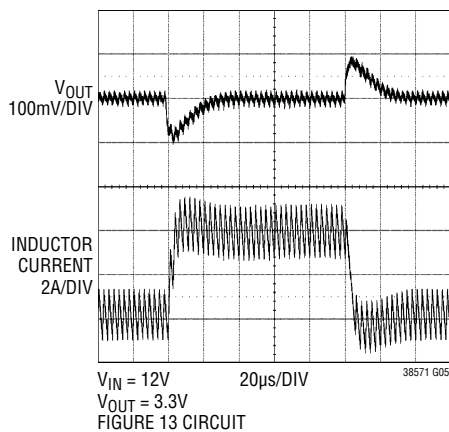

**Load Step (Pulse-Skipping Mode)**

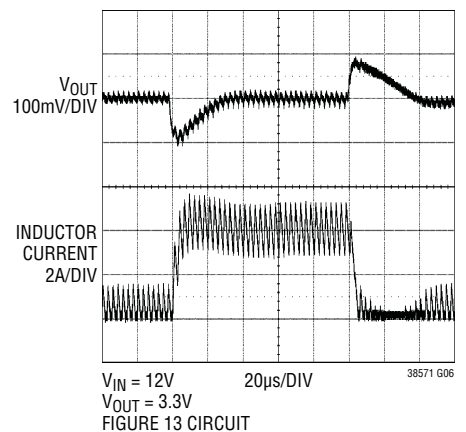

**Inductor Current at Light Load**

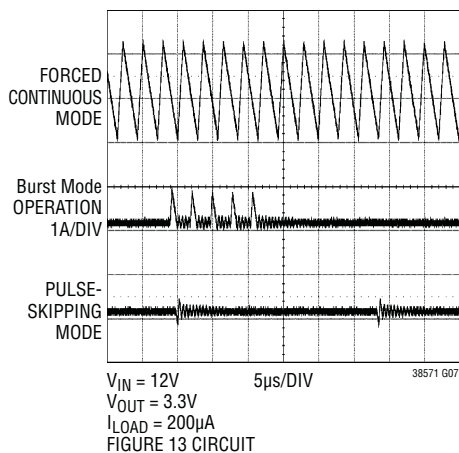

**Soft Start-Up**

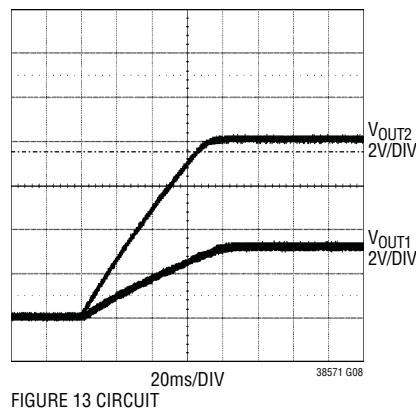

**Tracking Start-Up**

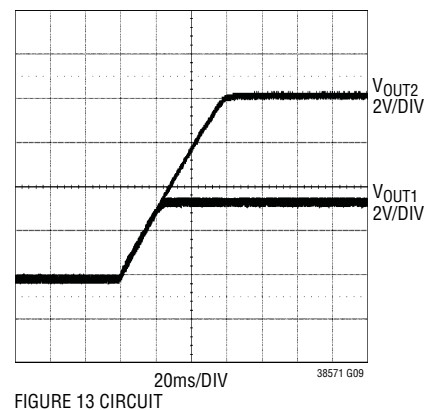

## TYPICAL PERFORMANCE CHARACTERISTICS

**Total Input Supply Current vs Input Voltage**

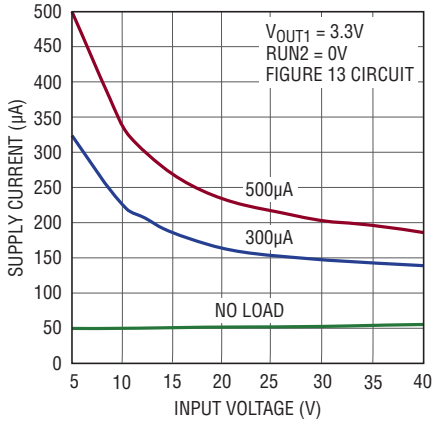

38571 G10

**EXTV<sub>CC</sub> Switchover and INTV<sub>CC</sub> Voltages vs Temperature**

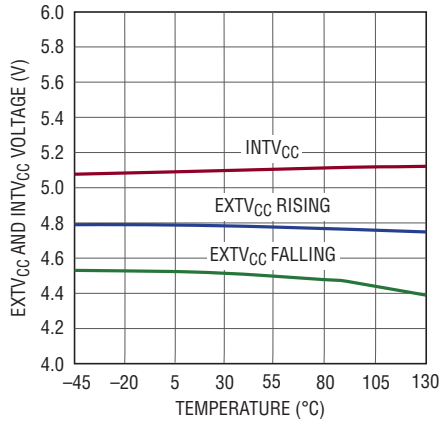

38571 G11

**INTV<sub>CC</sub> Line Regulation**

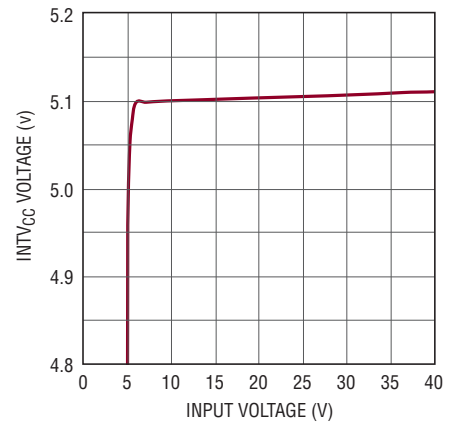

38571 G12

**Maximum Current Sense Voltage vs I<sub>TH</sub> Voltage**

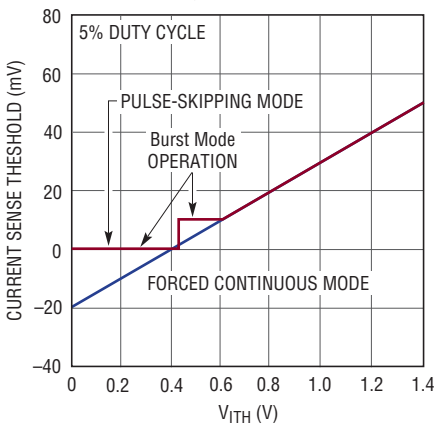

38571 G13

**SENSE<sup>-</sup> Pin Input Bias Current**

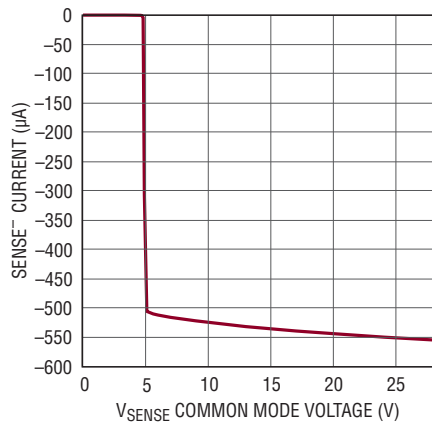

38571 G14

**Maximum Current Sense Threshold vs Duty Cycle**

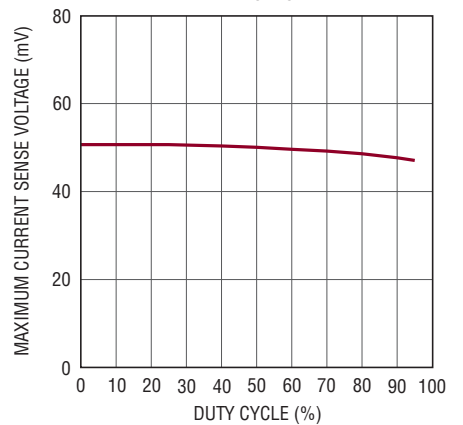

38571 G15

**Foldback Current Limit**

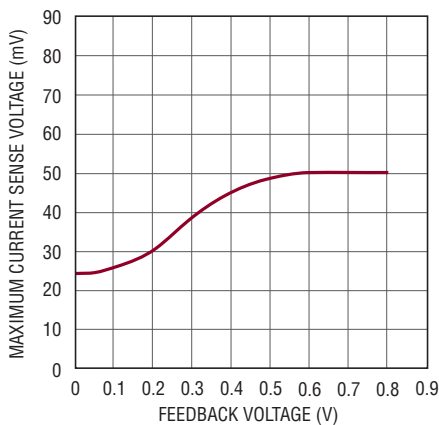

38571 G16

**Quiescent Current vs Temperature**

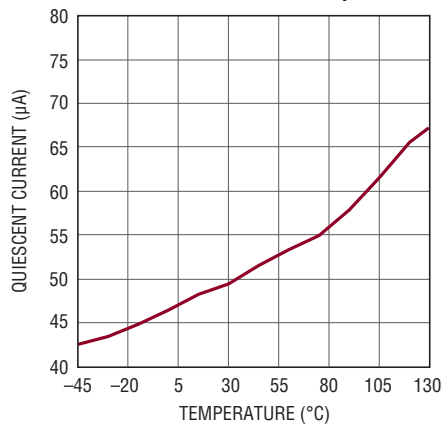

38571 G17

**INTV<sub>CC</sub> and EXTV<sub>CC</sub> vs Load Current**

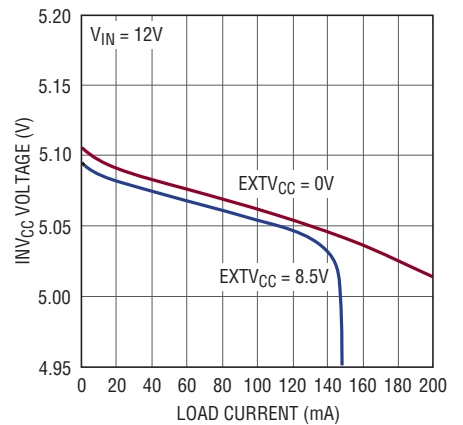

38571 G18

38571fc

# TYPICAL PERFORMANCE CHARACTERISTICS

**TRACK/SS Pull-Up Current vs Temperature**

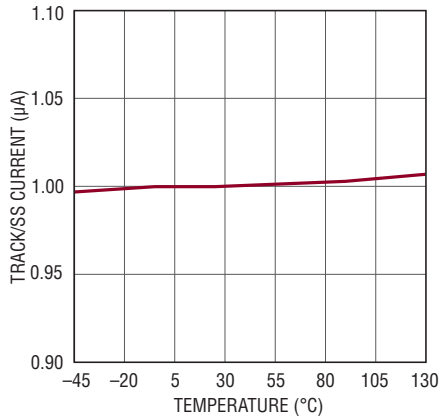

38571 G19

**Shutdown (RUN) Threshold vs Temperature**

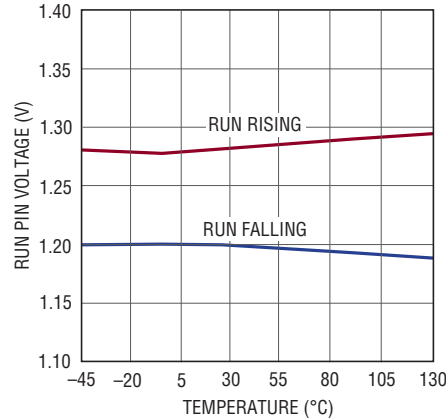

38571 G20

**Regulated Feedback Voltage vs Temperature**

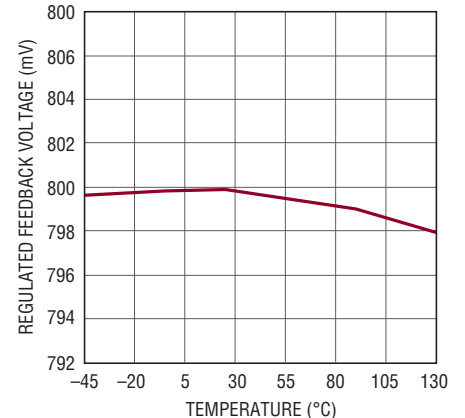

3857 G21

**SENSE<sup>-</sup> Pin Input Current vs Temperature**

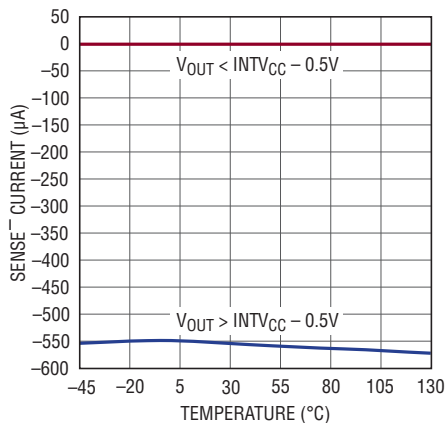

38571 G22

**Shutdown Current vs Input Voltage**

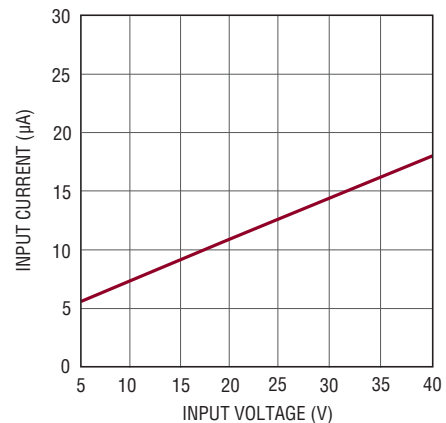

38571 G23

**Oscillator Frequency vs Temperature**

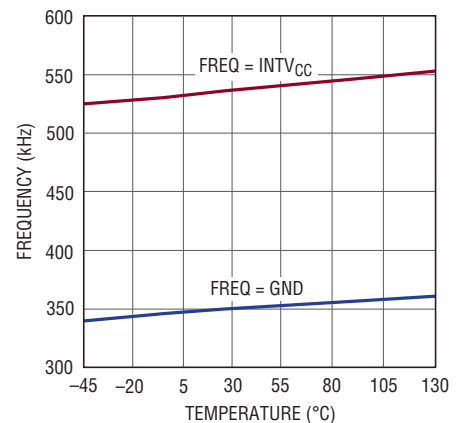

38571 G24

**Undervoltage Lockout Threshold vs Temperature**

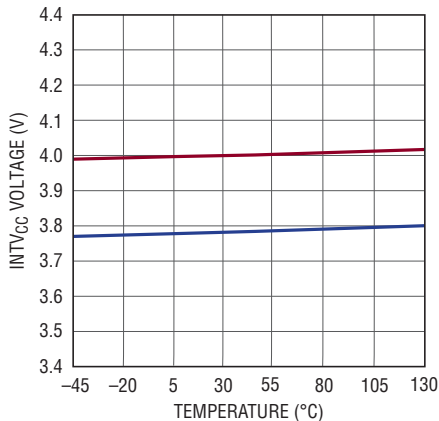

38571 G25

**Oscillator Frequency vs Input Voltage**

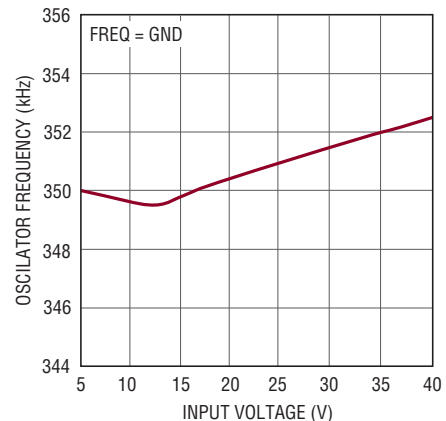

38571 G26

**Shutdown Current vs Temperature**

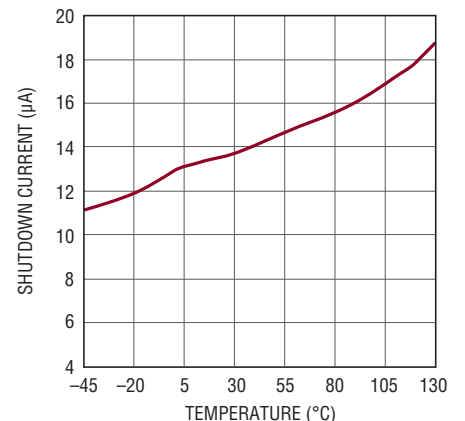

38571 G27

## PIN FUNCTIONS

**I<sub>TH1</sub>, I<sub>TH2</sub> (Pin 1, Pin 13):** Error Amplifier Outputs and Switching Regulator Compensation Points. Each associated channel's current comparator trip point increases with this control voltage.

**V<sub>FB1</sub>, V<sub>FB2</sub> (Pin 2, Pin 12):** Receives the remotely sensed feedback voltage for each controller from an external resistive divider across the output.

**SENSE1<sup>+</sup>, SENSE2<sup>+</sup> (Pin 3, Pin 11):** The (+) input to the differential current comparators are normally connected to DCR sensing networks or current sensing resistors. The I<sub>TH</sub> pin voltage and controlled offsets between the SENSE<sup>-</sup> and SENSE<sup>+</sup> pins in conjunction with R<sub>SENSE</sub> set the current trip threshold.

**SENSE1<sup>-</sup>, SENSE2<sup>-</sup> (Pin 4, Pin 10):** The (-) Input to the Differential Current Comparators. When greater than INTV<sub>CC</sub> - 0.5V, the SENSE<sup>-</sup> pin supplies current to the current comparator.

**FREQ (Pin 5):** The Frequency Control Pin for the Internal VCO. Connecting the pin to GND forces the VCO to a fixed low frequency of 350kHz. Connecting the pin to INTV<sub>CC</sub> forces the VCO to a fixed high frequency of 535kHz. Other frequencies between 50kHz and 900kHz can be programmed using a resistor between FREQ and GND. An internal 20μA pull-up current develops the voltage to be used by the VCO to control the frequency

**PLLIN/MODE (Pin 6):** External Synchronization Input to Phase Detector and Forced Continuous Mode Input. When an external clock is applied to this pin, the phase-locked loop will force the rising TG1 signal to be synchronized with the rising edge of the external clock. When not synchronizing to an external clock, this input, which acts on both controllers, determines how the LTC3857-1 operates at light loads. Pulling this pin to ground selects Burst Mode operation. An internal 100k resistor to ground also

invokes Burst Mode operation when the pin is floated. Tying this pin to INTV<sub>CC</sub> forces continuous inductor current operation. Tying this pin to a voltage greater than 1.2V and less than INTV<sub>CC</sub> - 1.3V selects pulse-skipping operation. This can be done by adding a 100k resistor between the PLLIN/MODE pin and INTV<sub>CC</sub>.

**SGND (Pin 7):** Small-signal ground common to both controllers, must be routed separately from high current grounds to the common (-) terminals of the C<sub>IN</sub> capacitors.

**RUN1, RUN2 (Pin 8, Pin 9):** Digital Run Control Inputs for Each Controller. Forcing either of these pins below 1.26V shuts down that controller. Forcing both of these pins below 0.7V shuts down the entire LTC3857-1, reducing quiescent current to approximately 8μA. Do not float these pins.

**INTV<sub>CC</sub> (Pin 19):** Output of the Internal Linear Low Dropout Regulator. The driver and control circuits are powered from this voltage source. Must be decoupled to power ground with a minimum of 4.7μF ceramic or other low ESR capacitor. Do not use the INTV<sub>CC</sub> pin for any other purpose.

**EXTV<sub>CC</sub> (Pin 20):** External Power Input to an Internal LDO Connected to INTV<sub>CC</sub>. This LDO supplies INTV<sub>CC</sub> power, bypassing the internal LDO powered from V<sub>IN</sub> whenever EXTV<sub>CC</sub> is higher than 4.7V. See EXTV<sub>CC</sub> Connection in the Applications Information section. Do not exceed 14V on this pin.

**PGND (Pin 21):** Driver Power Ground. Connects to the sources of bottom (synchronous) N-channel MOSFETs and the (-) terminal(s) of C<sub>IN</sub>.

**V<sub>IN</sub> (Pin 22):** Main Supply Pin. A bypass capacitor should be tied between this pin and the signal ground pin.

**BG1, BG2 (Pin 23, Pin 18):** High Current Gate Drives for Bottom (Synchronous) N-Channel MOSFETs. Voltage swing at these pins is from ground to INTV<sub>CC</sub>.

## PIN FUNCTIONS

**BOOST1, BOOST2 (Pin 24, Pin 17):** Bootstrapped Supplies to the Topside Floating Drivers. Capacitors are connected between the BOOST and SW pins and Schottky diodes are tied between the BOOST and INTV<sub>CC</sub> pins. Voltage swing at the BOOST pins is from INTV<sub>CC</sub> to ( $V_{IN} + \text{INTV}_{CC}$ ).

**SW1, SW2 (Pin 25, Pin 16):** Switch Node Connections to Inductors.

**TG1, TG2 (Pin 26, Pin 15):** High Current Gate Drives for Top N-Channel MOSFETs. These are the outputs of floating drivers with a voltage swing equal to  $\text{INTV}_{CC} - 0.5\text{V}$  superimposed on the switch node voltage SW.

**PGOOD1 (Pin 27):** Open-Drain Logic Output. PGOOD1 is pulled to ground when the voltage on the V<sub>FB1</sub> pin is not within  $\pm 10\%$  of its set point.

**TRACK/SS1, TRACK/SS2 (Pin 28, Pin 14):** External Tracking and Soft-Start Input. The LTC3857-1 regulates the V<sub>FB1,2</sub> voltage to the smaller of 0.8V or the voltage on the TRACK/SS1,2 pin. An internal 1 $\mu\text{A}$  pull-up current source is connected to this pin. A capacitor to ground at this pin sets the ramp time to final regulated output voltage. Alternatively, a resistor divider on another voltage supply connected to this pin allows the LTC3857-1 output to track the other supply during start-up.

FUNCTIONAL DIAGRAM

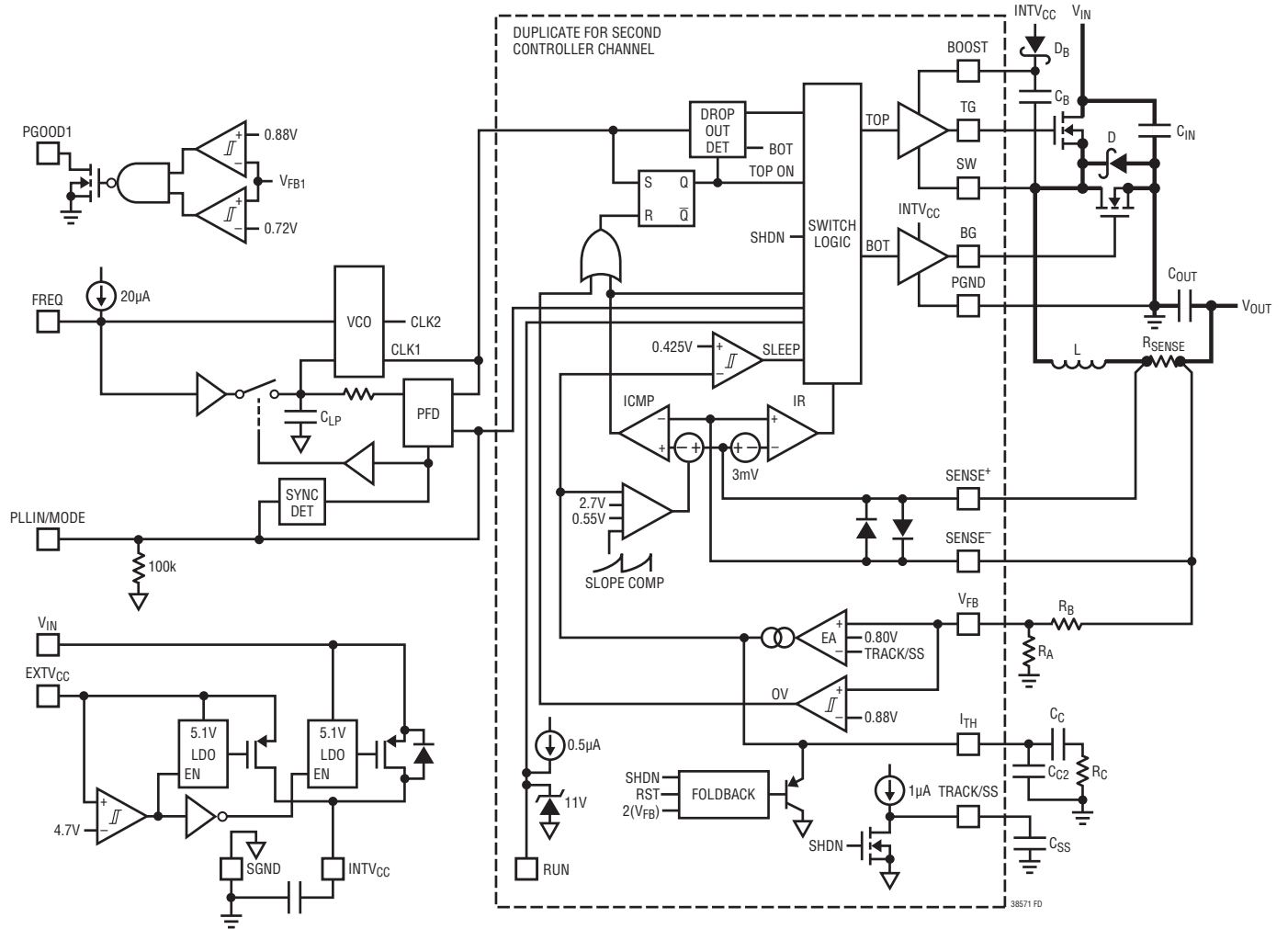

## OPERATION (Refer to the Functional Diagram)

### Main Control Loop

The LTC3857-1 uses a constant frequency, current mode step-down architecture with the two controller channels operating 180 degrees out of phase. During normal operation, each external top MOSFET is turned on when the clock for that channel sets the RS latch, and is turned off when the main current comparator, ICMP, resets the RS latch. The peak inductor current at which ICMP trips and resets the latch is controlled by the voltage on the  $I_{TH}$  pin, which is the output of the error amplifier, EA. The error amplifier compares the output voltage feedback signal at the  $V_{FB}$  pin, (which is generated with an external resistor divider connected across the output voltage,  $V_{OUT}$ , to ground) to the internal 0.800V reference voltage. When the load current increases, it causes a slight decrease in  $V_{FB}$  relative to the reference, which causes the EA to increase the  $I_{TH}$  voltage until the average inductor current matches the new load current.

After the top MOSFET is turned off each cycle, the bottom MOSFET is turned on until either the inductor current starts to reverse, as indicated by the current comparator IR, or the beginning of the next clock cycle.

### INTV<sub>CC</sub>/EXTV<sub>CC</sub> Power

Power for the top and bottom MOSFET drivers and most other internal circuitry is derived from the INTV<sub>CC</sub> pin. When the EXTV<sub>CC</sub> pin is left open or tied to a voltage less than 4.7V, the  $V_{IN}$  LDO (low dropout linear regulator) supplies 5.1V from  $V_{IN}$  to INTV<sub>CC</sub>. If EXTV<sub>CC</sub> is taken above 4.7V, the  $V_{IN}$  LDO is turned off and an EXTV<sub>CC</sub> LDO is turned on. Once enabled, the EXTV<sub>CC</sub> LDO supplies 5.1V from EXTV<sub>CC</sub> to INTV<sub>CC</sub>. Using the EXTV<sub>CC</sub> pin allows the INTV<sub>CC</sub> power to be derived from a high efficiency external source such as one of the LTC3857-1 switching regulator outputs.

Each top MOSFET driver is biased from the floating bootstrap capacitor  $C_B$ , which normally recharges during each cycle through an external diode when the top MOSFET turns off. If the input voltage,  $V_{IN}$ , decreases to a voltage close to  $V_{OUT}$ , the loop may enter dropout and attempt

to turn on the top MOSFET continuously. The dropout detector detects this and forces the top MOSFET off for about one-twelfth of the clock period every tenth cycle to allow  $C_B$  to recharge.

### Shutdown and Start-Up (RUN1, RUN2 and TRACK/SS1, TRACK/SS2 Pins)

The two channels of the LTC3857-1 can be independently shut down using the RUN1 and RUN2 pins. Pulling either of these pins below 1.26V shuts down the main control loop for that controller. Pulling both pins below 0.7V disables both controllers and most internal circuits, including the INTV<sub>CC</sub> LDOs. In this state, the LTC3857-1 draws only 8 $\mu$ A of quiescent current.

The RUN pin may be externally pulled up or driven directly by logic. When driving the RUN pin with a low impedance source, do not exceed the absolute maximum rating of 8V. The RUN pin has an internal 11V voltage clamp that allows the RUN pin to be connected through a resistor to a higher voltage (for example,  $V_{IN}$ ), so long as the maximum current into the RUN pin does not exceed 100 $\mu$ A.

The start-up of each controller's output voltage  $V_{OUT}$  is controlled by the voltage on the TRACK/SS pin for that channel. When the voltage on the TRACK/SS pin is less than the 0.8V internal reference, the LTC3857-1 regulates the  $V_{FB}$  voltage to the TRACK/SS pin voltage instead of the 0.8V reference. This allows the TRACK/SS pin to be used to program a soft-start by connecting an external capacitor from the TRACK/SS pin to SGND. An internal 1 $\mu$ A pull-up current charges this capacitor creating a voltage ramp on the TRACK/SS pin. As the TRACK/SS voltage rises linearly from 0V to 0.8V (and beyond up to the absolute maximum rating of 6V), the output voltage  $V_{OUT}$  rises smoothly from zero to its final value.

Alternatively the TRACK/SS pin can be used to cause the start-up of  $V_{OUT}$  to *track* that of another supply. Typically, this requires connecting to the TRACK/SS pin an external resistor divider from the other supply to ground (see Applications Information section).

## OPERATION (Refer to the Functional Diagram)

### Light Load Current Operation (Burst Mode Operation, Pulse-Skipping or Forced Continuous Mode) (PLLIN/MODE Pin)

The LTC3857-1 can be enabled to enter high efficiency Burst Mode operation, constant frequency pulse-skipping mode, or forced continuous conduction mode at low load currents. To select Burst Mode operation, tie the PLLIN/MODE pin to GND. To select forced continuous operation, tie the PLLIN/MODE pin to INTV<sub>CC</sub>. To select pulse-skipping mode, tie the PLLIN/MODE pin to a DC voltage greater than 1.2V and less than INTV<sub>CC</sub> – 1.3V.

When a controller is enabled for Burst Mode operation, the minimum peak current in the inductor is set to approximately 15% of the maximum sense voltage even though the voltage on the I<sub>TH</sub> pin indicates a lower value. If the average inductor current is higher than the load current, the error amplifier, EA, will decrease the voltage on the I<sub>TH</sub> pin. When the I<sub>TH</sub> voltage drops below 0.425V, the internal sleep signal goes high (enabling *sleep* mode) and both external MOSFETs are turned off. The I<sub>TH</sub> pin is then disconnected from the output of the EA and *parked* at 0.450V.

In sleep mode, much of the internal circuitry is turned off, reducing the quiescent current that the LTC3857-1 draws. If one channel is shut down and the other channel is in sleep mode, the LTC3857-1 draws only 50μA of quiescent current. If both channels are in sleep mode, the LTC3857-1 draws only 65μA of quiescent current. In sleep mode, the load current is supplied by the output capacitor. As the output voltage decreases, the EA's output begins to rise. When the output voltage drops enough, the I<sub>TH</sub> pin is reconnected to the output of the EA, the sleep signal goes low, and the controller resumes normal operation by turning on the top external MOSFET on the next cycle of the internal oscillator.

When a controller is enabled for Burst Mode operation, the inductor current is not allowed to reverse. The reverse current comparator, IR, turns off the bottom external MOSFET just before the inductor current reaches zero, preventing it from reversing and going negative. Thus, the controller operates in discontinuous operation.

In forced continuous operation or clocked by an external clock source to use the phase-locked loop (see Frequency Selection and Phase-Locked Loop section), the inductor current is allowed to reverse at light loads or under large transient conditions. The peak inductor current is determined by the voltage on the I<sub>TH</sub> pin, just as in normal operation. In this mode, the efficiency at light loads is lower than in Burst Mode operation. However, continuous operation has the advantage of lower output voltage ripple and less interference to audio circuitry. In forced continuous mode, the output ripple is independent of load current.

When the PLLIN/MODE pin is connected for pulse-skipping mode, the LTC3857-1 operates in PWM pulse-skipping mode at light loads. In this mode, constant frequency operation is maintained down to approximately 1% of designed maximum output current. At very light loads, the current comparator, ICMP, may remain tripped for several cycles and force the external top MOSFET to stay off for the same number of cycles (i.e., skipping pulses). The inductor current is not allowed to reverse (discontinuous operation). This mode, like forced continuous operation, exhibits low output ripple as well as low audio noise and reduced RF interference as compared to Burst Mode operation. It provides higher low current efficiency than forced continuous mode, but not nearly as high as Burst Mode operation.

### Frequency Selection and Phase-Locked Loop (FREQ and PLLIN/MODE Pins)

The selection of switching frequency is a trade-off between efficiency and component size. Low frequency operation increases efficiency by reducing MOSFET switching losses, but requires larger inductance and/or capacitance to maintain low output ripple voltage.

The switching frequency of the LTC3857-1's controllers can be selected using the FREQ pin.

If the PLLIN/MODE pin is not being driven by an external clock source, the FREQ pin can be tied to SGND, tied to INTV<sub>CC</sub> or programmed through an external resistor. Tying FREQ to SGND selects 350kHz while tying FREQ to INTV<sub>CC</sub> selects 535kHz. Placing a resistor between FREQ and

## OPERATION (Refer to the Functional Diagram)

SGND allows the frequency to be programmed between 50kHz and 900kHz.

A phase-locked loop (PLL) is available on the LTC3857-1 to synchronize the internal oscillator to an external clock source that is connected to the PLLIN/MODE pin. The phase detector adjusts the voltage (through an internal lowpass filter) of the VCO input to align the turn-on of controller 1's external top MOSFET to the rising edge of the synchronizing signal. Thus, the turn-on of controller 2's external top MOSFET is 180 degrees out of phase to the rising edge of the external clock source.

The VCO input voltage is prebiased to the operating frequency set by the FREQ pin before the external clock is applied. If prebiased near the external clock frequency, the PLL loop only needs to make slight changes to the VCO input in order to synchronize the rising edge of the external clock's to the rising edge of TG1. The ability to prebias the loop filter allows the PLL to lock-in rapidly without deviating far from the desired frequency.

The typical capture range of the phase-locked loop is from approximately 55kHz to 1MHz, with a guarantee over all manufacturing variations to be between 75kHz and 850kHz. In other words, the LTC3857-1's PLL is guaranteed to lock to an external clock source whose frequency is between 75kHz and 850kHz.

The typical input clock thresholds on the PLLIN/MODE pin are 1.6V (rising) and 1.1V (falling).

### Output Overvoltage Protection

An overvoltage comparator guards against transient overshoots as well as other more serious conditions that may overvoltage the output. When the  $V_{FB}$  pin rises by more than 10% above its regulation point of 0.800V, the top MOSFET is turned off and the bottom MOSFET is turned on until the overvoltage condition is cleared.

### Power Good (PGOOD1 Pin)

The PGOOD1 pin is connected to an open drain of an internal N-channel MOSFET. The MOSFET turns on and pulls the PGOOD1 pin low when the corresponding  $V_{FB1}$  pin voltage is not within  $\pm 10\%$  of the 0.8V reference voltage. The PGOOD1 pin is also pulled low when the corresponding RUN1 pin is low (shut down). When the  $V_{FB1}$  pin voltage is within the  $\pm 10\%$  requirement, the MOSFET is turned off and the pin is allowed to be pulled up by an external resistor to a source no greater than 6V.

### Foldback Current

When the output voltage falls to less than 70% of its nominal level, foldback current limiting is activated, progressively lowering the peak current limit in proportion to the severity of the overcurrent or short-circuit condition. Foldback current limiting is disabled during the soft-start interval (as long as the  $V_{FB}$  voltage is keeping up with the TRACK/SS voltage).

### Theory and Benefits of 2-Phase Operation

Why the need for 2-phase operation? Up until the 2-phase family, constant-frequency dual switching regulators operated both channels in phase (i.e., single phase operation). This means that both switches turned on at the same time, causing current pulses of up to twice the amplitude of those for one regulator to be drawn from the input capacitor and battery. These large amplitude current pulses increased the total RMS current flowing from the input capacitor, requiring the use of more expensive input capacitors and increasing both EMI and losses in the input capacitor and battery.

With 2-phase operation, the two channels of the dual switching regulator are operated 180 degrees out of phase. This effectively interleaves the current pulses drawn by the switches, greatly reducing the overlap time where they add

## OPERATION (Refer to the Functional Diagram)

together. The result is a significant reduction in total RMS input current, which in turn allows less expensive input capacitors to be used, reduces shielding requirements for EMI and improves real world operating efficiency.

Figure 1 compares the input waveforms for a single-phase dual switching regulator to a 2-phase dual switching regulator. An actual measurement of the RMS input current under these conditions shows that 2-phase operation dropped the input current from  $2.53A_{RMS}$  to  $1.55A_{RMS}$ . While this is an impressive reduction in itself, remember that the power losses are proportional to  $I_{RMS}^2$ , meaning that the actual power wasted is reduced by a factor of 2.66. The reduced input ripple voltage also means less power is lost in the input power path, which could include batteries, switches, trace/connector resistances and protection circuitry. Improvements in both conducted and radiated EMI also directly accrue as a result of the reduced RMS input current and voltage.

Of course, the improvement afforded by 2-phase operation is a function of the dual switching regulator's relative duty cycles which, in turn, are dependent upon the input voltage  $V_{IN}$  (Duty Cycle =  $V_{OUT}/V_{IN}$ ). Figure 2 shows how

the RMS input current varies for single phase and 2-phase operation for 3.3V and 5V regulators over a wide input voltage range.

It can readily be seen that the advantages of 2-phase operation are not just limited to a narrow operating range, for most applications is that 2-phase operation will reduce the input capacitor requirement to that for just one channel operating at maximum current and 50% duty cycle.

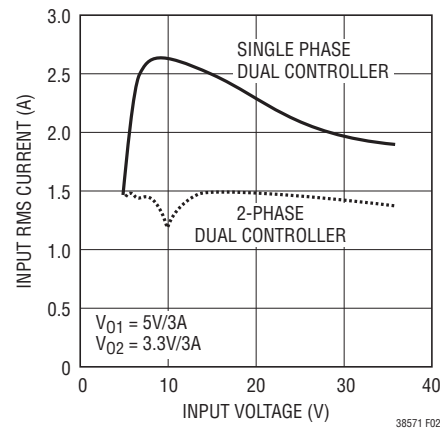

Figure 2. RMS Input Current Comparison

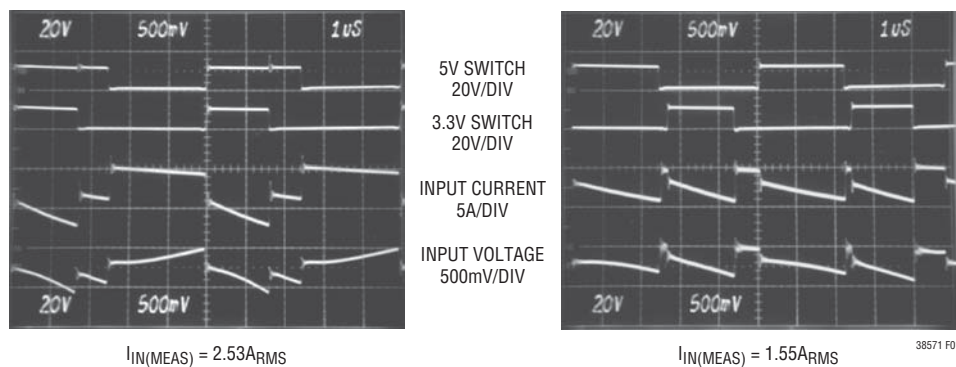

Figure 1. Input Waveforms Comparing Single-Phase (a) and 2-Phase (b) Operation for Dual Switching Regulators Converting 12V to 5V and 3.3V at 3A Each. The Reduced Input Ripple with the 2-Phase Regulator Allows Less Expensive Input Capacitors, Reduces Shielding Requirements for EMI and Improves Efficiency

## APPLICATIONS INFORMATION

The Typical Application on the first page is a basic LTC3857-1 application circuit. LTC3857-1 can be configured to use either DCR (inductor resistance) sensing or low value resistor sensing. The choice between the two current sensing schemes is largely a design trade-off between cost, power consumption, and accuracy. DCR sensing is becoming popular because it saves expensive current sensing resistors and is more power efficient, especially in high current applications. However, current sensing resistors provide the most accurate current limits for the controller. Other external component selection is driven by the load requirement, and begins with the selection of  $R_{SENSE}$  (if  $R_{SENSE}$  is used) and inductor value. Next, the power MOSFETs and Schottky diodes are selected. Finally, input and output capacitors are selected.

### SENSE+ and SENSE- Pins

The SENSE+ and SENSE- pins are the inputs to the current comparators. The common mode voltage range on these pins is 0V to 28V (abs max), enabling the LTC3857-1 to regulate output voltages up to a nominal 24V (allowing margin for tolerances and transients).

The SENSE+ pin is high impedance over the full common mode range, drawing at most  $\pm 1\mu\text{A}$ . This high impedance allows the current comparators to be used in inductor DCR sensing.

The impedance of the SENSE- pin changes depending on the common mode voltage. When SENSE- is less than  $\text{INTV}_{CC} - 0.5\text{V}$ , a small current of less than  $1\mu\text{A}$  flows out of the pin. When SENSE- is above  $\text{INTV}_{CC} + 0.5\text{V}$ , a higher current ( $\sim 550\mu\text{A}$ ) flows into the pin. Between  $\text{INTV}_{CC} - 0.5\text{V}$  and  $\text{INTV}_{CC} + 0.5\text{V}$ , the current transitions from the smaller current to the higher current.

Filter components mutual to the sense lines should be placed close to the LTC3857-1, and the sense lines should run close together to a Kelvin connection underneath the current sense element (shown in Figure 3). Sensing current elsewhere can effectively add parasitic inductance and capacitance to the current sense element, degrading the information at the sense terminals and making the

programmed current limit unpredictable. If inductor DCR sensing is used (Figure 4b), resistor R1 should be placed close to the switching node, to prevent noise from coupling into sensitive small-signal nodes.

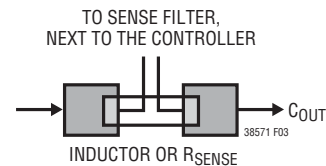
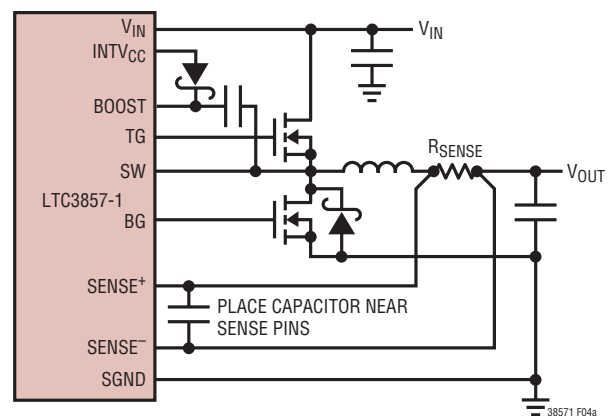
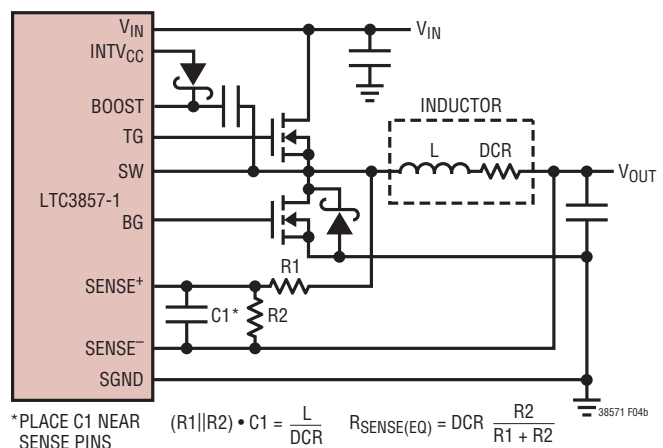

Figure 3. Sense Lines Placement with Inductor or Sense Resistor



(4a) Using a Resistor to Sense Current



(4b) Using the Inductor DCR to Sense Current

Figure 4. Current Sensing Methods

## APPLICATIONS INFORMATION

### Low Value Resistor Current Sensing

A typical sensing circuit using a discrete resistor is shown in Figure 4a.  $R_{\text{SENSE}}$  is chosen based on the required output current.

The current comparator has a maximum threshold  $V_{\text{SENSE(MAX)}}$ . The current comparator threshold voltage sets the peak of the inductor current, yielding a maximum average output current,  $I_{\text{MAX}}$ , equal to the peak value less half the peak-to-peak ripple current,  $\Delta I_L$ . To calculate the sense resistor value, use the equation:

$$R_{\text{SENSE}} = \frac{V_{\text{SENSE(MAX)}}}{I_{\text{MAX}} + \frac{\Delta I_L}{2}}$$

When using the controller in very low dropout conditions, the maximum output current level will be reduced due to the internal compensation required to meet stability criterion for buck regulators operating at greater than 50% duty factor. A curve is provided in the Typical Performance Characteristics section to estimate this reduction in peak output current depending upon the operating duty factor.

### Inductor DCR Sensing

For applications requiring the highest possible efficiency at high load currents, the LTC3857-1 is capable of sensing the voltage drop across the inductor DCR, as shown in Figure 4b. The DCR of the inductor represents the small amount of DC resistance of the copper wire, which can be less than 1m $\Omega$  for today's low value, high current inductors. In a high current application requiring such an inductor, power loss through a sense resistor would cost several points of efficiency compared to inductor DCR sensing.

If the external  $R1 \parallel R2 \cdot C1$  time constant is chosen to be exactly equal to the  $L/DCR$  time constant, the voltage

drop across the external capacitor is equal to the drop across the inductor DCR multiplied by  $R2/(R1 + R2)$ .  $R2$  scales the voltage across the sense terminals for applications where the DCR is greater than the target sense resistor value. To properly dimension the external filter components, the DCR of the inductor must be known. It can be measured using a good RLC meter, but the DCR tolerance is not always the same and varies with temperature; consult the manufacturers' data sheets for detailed information.

Using the inductor ripple current value from the Inductor Value Calculation section, the target sense resistor value is:

$$R_{\text{SENSE(EQUIV)}} = \frac{V_{\text{SENSE(MAX)}}}{I_{\text{MAX}} + \frac{\Delta I_L}{2}}$$

To ensure that the application will deliver full load current over the full operating temperature range, choose the minimum value for the maximum current sense threshold voltage ( $V_{\text{SENSE(MAX)}}$ ).

Next, determine the DCR of the inductor. When provided, use the manufacturer's maximum value, usually given at 20°C. Increase this value to account for the temperature coefficient of copper resistance, which is approximately 0.4%/°C. A conservative value for  $T_{L(\text{MAX})}$  is 100°C.

To scale the maximum inductor DCR to the desired sense resistor ( $R_D$ ) value, use the divider ratio:

$$R_D = \frac{R_{\text{SENSE(EQUIV)}}}{DCR_{\text{MAX}} \text{ at } T_{L(\text{MAX})}}$$

$C1$  is usually selected to be in the range of 0.1 $\mu\text{F}$  to 0.47 $\mu\text{F}$ . This forces  $R1 \parallel R2$  to around 2k, reducing error that might have been caused by the SENSE<sup>+</sup> pin's  $\pm 1\mu\text{A}$  current.

## APPLICATIONS INFORMATION

The equivalent resistance  $R1 \parallel R2$  is scaled to the room temperature inductance and maximum DCR:

$$R1 \parallel R2 = \frac{L}{(\text{DCR at } 20^\circ\text{C}) \cdot C1}$$

The sense resistor values are:

$$R1 = \frac{R1 \parallel R2}{R_D}; \quad R2 = \frac{R1 \cdot R_D}{1 - R_D}$$

The maximum power loss in R1 is related to duty cycle, and will occur in continuous mode at the maximum input voltage:

$$P_{\text{Loss } R1} = \frac{(V_{\text{IN(MAX)}} - V_{\text{OUT}}) \cdot V_{\text{OUT}}}{R1}$$

Ensure that R1 has a power rating higher than this value. If high efficiency is necessary at light loads, consider this power loss when deciding whether to use DCR sensing or sense resistors. Light load power loss can be modestly higher with a DCR network than with a sense resistor, due to the extra switching losses incurred through R1. However, DCR sensing eliminates a sense resistor, reduces conduction losses and provides higher efficiency at heavy loads. Peak efficiency is about the same with either method.

### Inductor Value Calculation

The operating frequency and inductor selection are inter-related in that higher operating frequencies allow the use of smaller inductor and capacitor values. So why would anyone ever choose to operate at lower frequencies with larger components? The answer is efficiency. A higher frequency generally results in lower efficiency because of MOSFET gate charge losses. In addition to this basic trade-off, the effect of inductor value on ripple current and low current operation must also be considered.

The inductor value has a direct effect on ripple current. The inductor ripple current,  $\Delta I_L$ , decreases with higher inductance or higher frequency and increases with higher  $V_{\text{IN}}$ :

$$\Delta I_L = \frac{1}{(f)(L)} V_{\text{OUT}} \left( 1 - \frac{V_{\text{OUT}}}{V_{\text{IN}}} \right)$$

Accepting larger values of  $\Delta I_L$  allows the use of low inductances, but results in higher output voltage ripple and greater core losses. A reasonable starting point for setting ripple current is  $\Delta I_L = 0.3(I_{\text{MAX}})$ . The maximum  $\Delta I_L$  occurs at the maximum input voltage.

The inductor value also has secondary effects. The transition to Burst Mode operation begins when the average inductor current required results in a peak current below 15% of the current limit determined by  $R_{\text{SENSE}}$ . Lower inductor values (higher  $\Delta I_L$ ) will cause this to occur at lower load currents, which can cause a dip in efficiency in the upper range of low current operation. In Burst Mode operation, lower inductance values will cause the burst frequency to decrease.

### Inductor Core Selection

Once the value for L is known, the type of inductor must be selected. High efficiency converters generally cannot afford the core loss found in low cost powdered iron cores, forcing the use of more expensive ferrite or molypermalloy cores. Actual core loss is independent of core size for a fixed inductor value, but it is very dependent on inductance value selected. As inductance increases, core losses go down. Unfortunately, increased inductance requires more turns of wire and therefore copper losses will increase.

Ferrite designs have very low core loss and are preferred for high switching frequencies, so design goals can concentrate on copper loss and preventing saturation. Ferrite core material saturates *hard*, which means that inductance collapses abruptly when the peak design current is exceeded. This results in an abrupt increase in inductor ripple current and consequent output voltage ripple. Do not allow the core to saturate!

### Power MOSFET and Schottky Diode (Optional) Selection

Two external power MOSFETs must be selected for each controller in the LTC3857-1: one N-channel MOSFET for the top (main) switch, and one N-channel MOSFET for the bottom (synchronous) switch.

## APPLICATIONS INFORMATION

The peak-to-peak drive levels are set by the  $INTV_{CC}$  voltage. This voltage is typically 5.1V during start-up (see  $EXTV_{CC}$  Pin Connection). Consequently, logic-level threshold MOSFETs must be used in most applications. The only exception is if low input voltage is expected ( $V_{IN} < 4V$ ); then, sub-logic level threshold MOSFETs ( $V_{GS(TH)} < 3V$ ) should be used. Pay close attention to the  $BV_{DSS}$  specification for the MOSFETs as well; many of the logic-level MOSFETs are limited to 30V or less.

Selection criteria for the power MOSFETs include the on-resistance,  $R_{DS(ON)}$ , Miller capacitance,  $C_{MILLER}$ , input voltage and maximum output current. Miller capacitance,  $C_{MILLER}$ , can be approximated from the gate charge curve usually provided on the MOSFET manufacturers' data sheet.  $C_{MILLER}$  is equal to the increase in gate charge along the horizontal axis while the curve is approximately flat divided by the specified change in  $V_{DS}$ . This result is then multiplied by the ratio of the application applied  $V_{DS}$  to the Gate charge curve specified  $V_{DS}$ . When the IC is operating in continuous mode the duty cycles for the top and bottom MOSFETs are given by:

$$\text{Main Switch Duty Cycle} = \frac{V_{OUT}}{V_{IN}}$$

$$\text{Synchronous Switch Duty Cycle} = \frac{V_{IN} - V_{OUT}}{V_{IN}}$$

The MOSFET power dissipations at maximum output current are given by:

$$P_{MAIN} = \frac{V_{OUT}}{V_{IN}} (I_{MAX})^2 (1 + \delta) R_{DS(ON)} + (V_{IN})^2 \left( \frac{I_{MAX}}{2} \right) (R_{DR}) (C_{MILLER}) \cdot \left[ \frac{1}{V_{INTVCC} - V_{THMIN}} + \frac{1}{V_{THMIN}} \right] (f)$$

$$P_{SYNC} = \frac{V_{IN} - V_{OUT}}{V_{IN}} (I_{MAX})^2 (1 + \delta) R_{DS(ON)}$$

where  $\delta$  is the temperature dependency of  $R_{DS(ON)}$  and  $R_{DR}$  (approximately  $2\Omega$ ) is the effective driver resistance at the MOSFET's Miller threshold voltage.  $V_{THMIN}$  is the typical MOSFET minimum threshold voltage.

Both MOSFETs have  $I^2R$  losses while the topside N-channel equation includes an additional term for transition losses, which are highest at high input voltages. For  $V_{IN} < 20V$  the high current efficiency generally improves with larger MOSFETs, while for  $V_{IN} > 20V$  the transition losses rapidly increase to the point that the use of a higher  $R_{DS(ON)}$  device with lower  $C_{MILLER}$  actually provides higher efficiency. The synchronous MOSFET losses are greatest at high input voltage when the top switch duty factor is low or during a short-circuit when the synchronous switch is on close to 100% of the period.

The term  $(1 + \delta)$  is generally given for a MOSFET in the form of a normalized  $R_{DS(ON)}$  vs Temperature curve, but  $\delta = 0.005/^\circ C$  can be used as an approximation for low voltage MOSFETs.

The optional Schottky diodes D1 and D2 shown in Figure 11 conduct during the dead-time between the conduction of the two power MOSFETs. This prevents the body diode of the bottom MOSFET from turning on, storing charge during the dead-time and requiring a reverse recovery period that could cost as much as 3% in efficiency at high  $V_{IN}$ . A 1A to 3A Schottky is generally a good compromise for both regions of operation due to the relatively small average current. Larger diodes result in additional transition losses due to their larger junction capacitance.

### $C_{IN}$ and $C_{OUT}$ Selection

The selection of  $C_{IN}$  is simplified by the 2-phase architecture and its impact on the worst-case RMS current drawn through the input network (battery/fuse/capacitor). It can be shown that the worst-case capacitor RMS current occurs when only one controller is operating. The controller with the highest  $(V_{OUT})(I_{OUT})$  product needs to be used in the formula shown in Equation 1 to determine the maximum

## APPLICATIONS INFORMATION

RMS capacitor current requirement. Increasing the output current drawn from the other controller will actually decrease the input RMS ripple current from its maximum value. The out-of-phase technique typically reduces the input capacitor's RMS ripple current by a factor of 30% to 70% when compared to a single phase power supply solution.

In continuous mode, the source current of the top MOSFET is a square wave of duty cycle  $(V_{OUT})/(V_{IN})$ . To prevent large voltage transients, a low ESR capacitor sized for the maximum RMS current of one channel must be used. The maximum RMS capacitor current is given by:

$$C_{IN} \text{ Required } I_{RMS} \approx \frac{I_{MAX}}{V_{IN}} [(V_{OUT})(V_{IN} - V_{OUT})]^{1/2} \quad (1)$$

This formula has a maximum at  $V_{IN} = 2V_{OUT}$ , where  $I_{RMS} = I_{OUT}/2$ . This simple worst-case condition is commonly used for design because even significant deviations do not offer much relief. Note that capacitor manufacturers' ripple current ratings are often based on only 2000 hours of life. This makes it advisable to further derate the capacitor, or to choose a capacitor rated at a higher temperature than required. Several capacitors may be paralleled to meet size or height requirements in the design. Due to the high operating frequency of the LTC3857-1, ceramic capacitors can also be used for  $C_{IN}$ . Always consult the manufacturer if there is any question.

The benefit of the LTC3857-1 2-phase operation can be calculated by using Equation 1 for the higher power controller and then calculating the loss that would have resulted if both controller channels switched on at the same time. The total RMS power lost is lower when both controllers are operating due to the reduced overlap of current pulses required through the input capacitor's ESR. This is why the input capacitor's requirement calculated above for the worst-case controller is adequate for the dual controller design. Also, the input protection fuse resistance, battery resistance, and PC board trace resistance losses are also reduced due to the reduced peak currents in a 2-phase system. The overall benefit of a multiphase design will only be fully realized when the source impedance of the power supply/battery is included in the efficiency testing. The drains of the top MOSFETs should be placed within

1cm of each other and share a common  $C_{IN}(s)$ . Separating the drains and  $C_{IN}$  may produce undesirable voltage and current resonances at  $V_{IN}$ .

A small (0.1 $\mu$ F to 1 $\mu$ F) bypass capacitor between the chip  $V_{IN}$  pin and ground, placed close to the LTC3857-1, is also suggested. A 10 $\Omega$  resistor placed between  $C_{IN}$  (C1) and the  $V_{IN}$  pin provides further isolation between the two channels.

The selection of  $C_{OUT}$  is driven by the effective series resistance (ESR). Typically, once the ESR requirement is satisfied, the capacitance is adequate for filtering. The output ripple ( $\Delta V_{OUT}$ ) is approximated by:

$$\Delta V_{OUT} \approx \Delta I_L \left( \text{ESR} + \frac{1}{8 \cdot f \cdot C_{OUT}} \right)$$

where  $f$  is the operating frequency,  $C_{OUT}$  is the output capacitance and  $\Delta I_L$  is the ripple current in the inductor. The output ripple is highest at maximum input voltage since  $\Delta I_L$  increases with input voltage.

### Setting Output Voltage

The LTC3857-1 output voltages are each set by an external feedback resistor divider carefully placed across the output, as shown in Figure 5. The regulated output voltage is determined by:

$$V_{OUT} = 0.8V \left( 1 + \frac{R_B}{R_A} \right)$$

To improve the frequency response, a feedforward capacitor,  $C_{FF}$ , may be used. Great care should be taken to route the  $V_{FB}$  line away from noise sources, such as the inductor or the SW line.

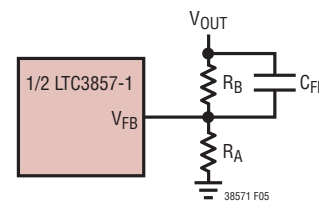

Figure 5. Setting Output Voltage

## APPLICATIONS INFORMATION

### Tracking and Soft-Start (TRACK/SS Pins)

The start-up of each  $V_{OUT}$  is controlled by the voltage on the respective TRACK/SS pin. When the voltage on the TRACK/SS pin is less than the internal 0.8V reference, the LTC3857-1 regulates the  $V_{FB}$  pin voltage to the voltage on the TRACK/SS pin instead of 0.8V. The TRACK/SS pin can be used to program an external soft-start function or to allow  $V_{OUT}$  to *track* another supply during start-up.

Soft-start is enabled by simply connecting a capacitor from the TRACK/SS pin to ground, as shown in Figure 6. An internal  $1\mu\text{A}$  current source charges the capacitor, providing a linear ramping voltage at the TRACK/SS pin. The LTC3857-1 will regulate the  $V_{FB}$  pin (and hence  $V_{OUT}$ ) according to the voltage on the TRACK/SS pin, allowing  $V_{OUT}$  to rise smoothly from 0V to its final regulated value. The total soft-start time will be approximately:

$$t_{SS} = C_{SS} \cdot \frac{0.8\text{V}}{1\mu\text{A}}$$

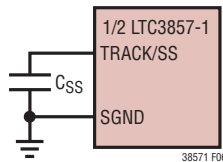

Figure 6. Using the TRACK/SS Pin to Program Soft-Start

Alternatively, the TRACK/SS pin can be used to track two (or more) supplies during start-up, as shown qualitatively in Figures 7a and 7b. To do this, a resistor divider should be connected from the master supply ( $V_X$ ) to the TRACK/SS pin of the slave supply ( $V_{OUT}$ ), as shown in Figure 8. During start-up  $V_{OUT}$  will track  $V_X$  according to the ratio set by the resistor divider:

$$\frac{V_X}{V_{OUT}} = \frac{R_A}{R_{TRACKA}} \cdot \frac{R_{TRACKA} + R_{TRACKB}}{R_A + R_B}$$

For coincident tracking ( $V_{OUT} = V_X$  during start-up):

$$R_A = R_{TRACKA}$$

$$R_B = R_{TRACKB}$$

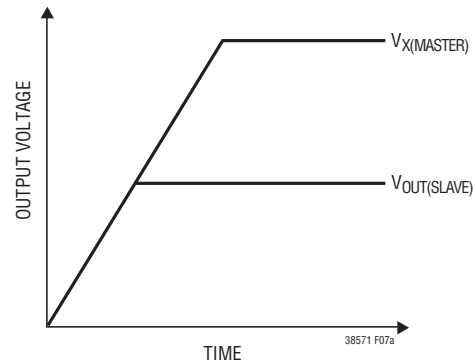

(7a) Coincident Tracking

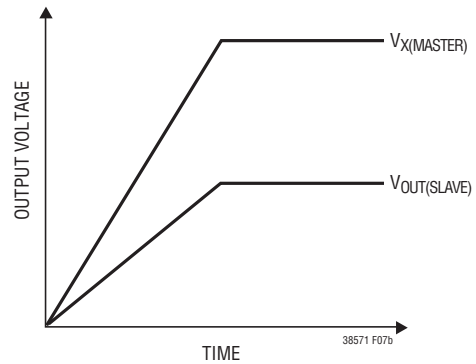

(7b) Ratiometric Tracking

Figure 7. Two Different Modes of Output Voltage Tracking

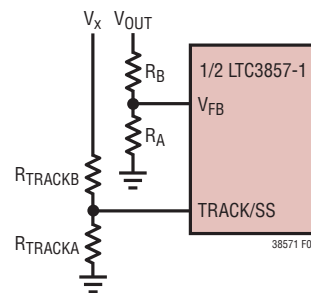

Figure 8. Using the TRACK/SS Pin for Tracking

## APPLICATIONS INFORMATION

### INTV<sub>CC</sub> Regulators

The LTC3857-1 features two separate internal P-channel low dropout linear regulators (LDO) that supply power at the INTV<sub>CC</sub> pin from either the V<sub>IN</sub> supply pin or the EXTV<sub>CC</sub> pin depending on the connection of the EXTV<sub>CC</sub> pin. INTV<sub>CC</sub> powers the gate drivers and much of the LTC3857-1's internal circuitry. The V<sub>IN</sub> LDO and the EXTV<sub>CC</sub> LDO regulate INTV<sub>CC</sub> to 5.1V. Each of these can supply a peak current of 50mA and must be bypassed to ground with a minimum of 4.7μF ceramic capacitor. No matter what type of bulk capacitor is used, an additional 1μF ceramic capacitor placed directly adjacent to the INTV<sub>CC</sub> and PGND pins is highly recommended. Good bypassing is needed to supply the high transient currents required by the MOSFET gate drivers and to prevent interaction between the channels.

High input voltage applications in which large MOSFETs are being driven at high frequencies may cause the maximum junction temperature rating for the LTC3857-1 to be exceeded. The INTV<sub>CC</sub> current, which is dominated by the gate charge current, may be supplied by either the V<sub>IN</sub> LDO or the EXTV<sub>CC</sub> LDO. When the voltage on the EXTV<sub>CC</sub> pin is less than 4.7V, the V<sub>IN</sub> LDO is enabled. Power dissipation for the IC in this case is highest and is equal to V<sub>IN</sub> • I<sub>INTVCC</sub>. The gate charge current is dependent on operating frequency as discussed in the Efficiency Considerations section. The junction temperature can be estimated by using the equations given in Note 3 of the Electrical Characteristics. For example, the LTC3857-1 INTV<sub>CC</sub> current is limited to less than 15mA from a 40V supply when not using the EXTV<sub>CC</sub> supply at a 70°C ambient temperature:

$$T_J = 70^\circ\text{C} + (15\text{mA})(40\text{V})(90^\circ\text{C}/\text{W}) = 125^\circ\text{C}$$

To prevent the maximum junction temperature from being exceeded, the input supply current must be checked while operating in forced continuous mode (PLLIN/MODE = INTV<sub>CC</sub>) at maximum V<sub>IN</sub>.

When the voltage applied to EXTV<sub>CC</sub> rises above 4.7V, the V<sub>IN</sub> LDO is turned off and the EXTV<sub>CC</sub> LDO is enabled. The EXTV<sub>CC</sub> LDO remains on as long as the voltage applied to EXTV<sub>CC</sub> remains above 4.5V. The EXTV<sub>CC</sub> LDO attempts

to regulate the INTV<sub>CC</sub> voltage to 5.1V, so while EXTV<sub>CC</sub> is less than 5.1V, the LDO is in dropout and the INTV<sub>CC</sub> voltage is approximately equal to EXTV<sub>CC</sub>. When EXTV<sub>CC</sub> is greater than 5.1V, up to an absolute maximum of 14V, INTV<sub>CC</sub> is regulated to 5.1V.

Using the EXTV<sub>CC</sub> LDO allows the MOSFET driver and control power to be derived from one of the LTC3857-1's switching regulator outputs (4.7V ≤ V<sub>OUT</sub> ≤ 14V) during normal operation and from the V<sub>IN</sub> LDO when the output is out of regulation (e.g., start-up, short-circuit). If more current is required through the EXTV<sub>CC</sub> LDO than is specified, an external Schottky diode can be added between the EXTV<sub>CC</sub> and INTV<sub>CC</sub> pins. In this case, do not apply more than 6V to the EXTV<sub>CC</sub> pin and make sure that EXTV<sub>CC</sub> ≤ V<sub>IN</sub>.

Significant efficiency and thermal gains can be realized by powering INTV<sub>CC</sub> from the output, since the V<sub>IN</sub> current resulting from the driver and control currents will be scaled by a factor of (Duty Cycle)/(Switcher Efficiency). For 5V to 14V regulator outputs, this means connecting the EXTV<sub>CC</sub> pin directly to V<sub>OUT</sub>. Tying the EXTV<sub>CC</sub> pin to an 8.5V supply reduces the junction temperature in the previous example from 125°C to:

$$T_J = 70^\circ\text{C} + (15\text{mA})(8.5\text{V})(90^\circ\text{C}/\text{W}) = 82^\circ\text{C}$$

However, for 3.3V and other low voltage outputs, additional circuitry is required to derive INTV<sub>CC</sub> power from the output.

The following list summarizes the four possible connections for EXTV<sub>CC</sub>:

1. EXTV<sub>CC</sub> Left Open (or Grounded). This will cause INTV<sub>CC</sub> to be powered from the internal 5.1V regulator resulting in an efficiency penalty of up to 10% at high input voltages.
2. EXTV<sub>CC</sub> Connected directly to V<sub>OUT</sub>. This is the normal connection for a 5V to 14V regulator and provides the highest efficiency.
3. EXTV<sub>CC</sub> Connected to an External supply. If an external supply is available in the 5V to 14V range, it may be used to power EXTV<sub>CC</sub>. Ensure that EXTV<sub>CC</sub> < V<sub>IN</sub>.



## APPLICATIONS INFORMATION

### Phase-Locked Loop and Frequency Synchronization

The LTC3857-1 has an internal phase-locked loop (PLL) comprised of a phase frequency detector, a lowpass filter, and a voltage-controlled oscillator (VCO). This allows the turn-on of the top MOSFET of controller 1 to be locked to the rising edge of an external clock signal applied to the PLLIN/MODE pin. The turn-on of controller 2's top MOSFET is thus 180 degrees out of phase with the external clock. The phase detector is an edge sensitive digital type that provides zero degrees phase shift between the external and internal oscillators. This type of phase detector does not exhibit false lock to harmonics of the external clock.

If the external clock frequency is greater than the internal oscillator's frequency,  $f_{OSC}$ , then current is sourced continuously from the phase detector output, pulling up the VCO input. When the external clock frequency is less than  $f_{OSC}$ , current is sunk continuously, pulling down the VCO input. If the external and internal frequencies are the same but exhibit a phase difference, the current sources turn on for an amount of time corresponding to the phase difference. The voltage at the VCO input is adjusted until the phase and frequency of the internal and external oscillators are identical. At the stable operating point, the phase detector output is high impedance and the internal filter capacitor, CLP, holds the voltage at the VCO input.

Note that the LTC3857-1 can only be synchronized to an external clock whose frequency is within range of the LTC3857-1's internal VCO, which is nominally 55kHz to 1MHz. This is guaranteed to be between 75kHz and 850kHz.

Typically, the external clock (on the PLLIN/MODE pin) input high threshold is 1.6V, while the input low threshold is 1.1V.

Rapid phase locking can be achieved by using the FREQ pin to set a free-running frequency near the desired

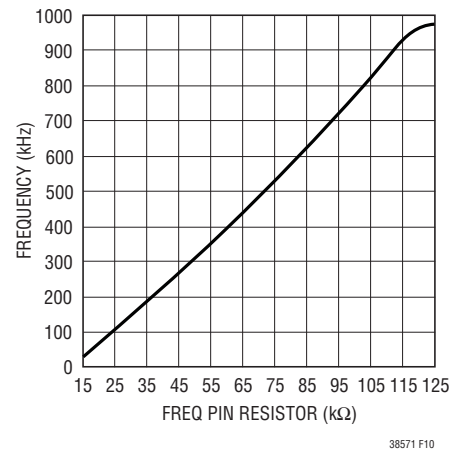

**Figure 10. Relationship Between Oscillator Frequency and Resistor Value at the FREQ Pin**

synchronization frequency. The VCO's input voltage is prebiased at a frequency corresponding to the frequency set by the FREQ pin. Once prebiased, the PLL only needs to adjust the frequency slightly to achieve phase lock and synchronization. Although it is not required that the free-running frequency be near external clock frequency, doing so will prevent the operating frequency from passing through a large range of frequencies as the PLL locks.

Table 2 summarizes the different states in which the FREQ pin can be used.

**Table 2**

FREQ PIN	PLLIN/MODE PIN	FREQUENCY
0V	DC Voltage	350kHz
INTV <sub>CC</sub>	DC Voltage	535kHz
Resistor	DC Voltage	50kHz–900kHz
Any of the Above	External Clock	Phase –Locked to External Clock

## APPLICATIONS INFORMATION

### Minimum On-Time Considerations

Minimum on-time,  $t_{ON(MIN)}$ , is the smallest time duration that the LTC3857-1 is capable of turning on the top MOSFET. It is determined by internal timing delays and the gate charge required to turn on the top MOSFET. Low duty cycle applications may approach this minimum on-time limit and care should be taken to ensure that

$$t_{ON(MIN)} < \frac{V_{OUT}}{V_{IN}(f)}$$

If the duty cycle falls below what can be accommodated by the minimum on-time, the controller will begin to skip cycles. The output voltage will continue to be regulated, but the ripple voltage and current will increase.

The minimum on-time for the LTC3857-1 is approximately 95ns. However, as the peak sense voltage decreases the minimum on-time gradually increases up to about 130ns. This is of particular concern in forced continuous applications with low ripple current at light loads. If the duty cycle drops below the minimum on-time limit in this situation, a significant amount of cycle skipping can occur with correspondingly larger current and voltage ripple.

### Efficiency Considerations

The percent efficiency of a switching regulator is equal to the output power divided by the input power times 100%. It is often useful to analyze individual losses to determine what is limiting the efficiency and which change would produce the most improvement. Percent efficiency can be expressed as:

$$\% \text{Efficiency} = 100\% - (L1 + L2 + L3 + \dots)$$

where L1, L2, etc. are the individual losses as a percentage of input power.

Although all dissipative elements in the circuit produce losses, four main sources usually account for most of the losses in LTC3857-1 circuits: 1) IC  $V_{IN}$  current, 2)  $INTV_{CC}$  regulator current, 3)  $I^2R$  losses, 4) topside MOSFET transition losses.

1. The  $V_{IN}$  current is the DC input supply current given in the Electrical Characteristics table, which excludes

MOSFET driver and control currents.  $V_{IN}$  current typically results in a small (<0.1%) loss.

2.  $INTV_{CC}$  current is the sum of the MOSFET driver and control currents. The MOSFET driver current results from switching the gate capacitance of the power MOSFETs. Each time a MOSFET gate is switched from low to high to low again, a packet of charge,  $dQ$ , moves from  $INTV_{CC}$  to ground. The resulting  $dQ/dt$  is a current out of  $INTV_{CC}$  that is typically much larger than the control circuit current. In continuous mode,  $I_{GATECHG} = f(Q_T + Q_B)$ , where  $Q_T$  and  $Q_B$  are the gate charges of the topside and bottom side MOSFETs.

Supplying  $INTV_{CC}$  from an output-derived power source through  $EXTV_{CC}$  will scale the  $V_{IN}$  current required for the driver and control circuits by a factor of (Duty Cycle)/(Efficiency). For example, in a 20V to 5V application, 10mA of  $INTV_{CC}$  current results in approximately 2.5mA of  $V_{IN}$  current. This reduces the midcurrent loss from 10% or more (if the driver was powered directly from  $V_{IN}$ ) to only a few percent.

3.  $I^2R$  losses are predicted from the DC resistances of the fuse (if used), MOSFET, inductor, current sense resistor, and input and output capacitor ESR. In continuous mode the average output current flows through L and  $R_{SENSE}$ , but is *chopped* between the topside MOSFET and the synchronous MOSFET. If the two MOSFETs have approximately the same  $R_{DS(ON)}$ , then the resistance of one MOSFET can simply be summed with the resistances of L,  $R_{SENSE}$  and ESR to obtain  $I^2R$  losses. For example, if each  $R_{DS(ON)} = 30m\Omega$ ,  $R_L = 50m\Omega$ ,  $R_{SENSE} = 10m\Omega$  and  $R_{ESR} = 40m\Omega$  (sum of both input and output capacitance losses), then the total resistance is 130m $\Omega$ . This results in losses ranging from 3% to 13% as the output current increases from 1A to 5A for a 5V output, or a 4% to 20% loss for a 3.3V output. Efficiency varies as the inverse square of  $V_{OUT}$  for the same external components and output power level. The combined effects of increasingly lower output voltages and higher currents required by high performance digital systems is not doubling but quadrupling the importance of loss terms in the switching regulator system!

## APPLICATIONS INFORMATION

4. Transition losses apply only to the topside MOSFET(s), and become significant only when operating at high input voltages (typically 15V or greater). Transition losses can be estimated from:

$$\text{Transition Loss} = (1.7) \cdot V_{\text{IN}} \cdot 2 \cdot I_{\text{O(MAX)}} \cdot C_{\text{RSS}} \cdot f$$

Other *hidden* losses such as copper trace and internal battery resistances can account for an additional 5% to 10% efficiency degradation in portable systems. It is very important to include these *system* level losses during the design phase. The internal battery and fuse resistance losses can be minimized by making sure that  $C_{\text{IN}}$  has adequate charge storage and very low ESR at the switching frequency. A 25W supply will typically require a minimum of 20 $\mu\text{F}$  to 40 $\mu\text{F}$  of capacitance having a maximum of 20m $\Omega$  to 50m $\Omega$  of ESR. The LTC3857-1 2-phase architecture typically halves this input capacitance requirement over competing solutions. Other losses including Schottky conduction losses during dead-time and inductor core losses generally account for less than 2% total additional loss.

### Checking Transient Response

The regulator loop response can be checked by looking at the load current transient response. Switching regulators take several cycles to respond to a step in DC (resistive) load current. When a load step occurs,  $V_{\text{OUT}}$  shifts by an amount equal to  $\Delta I_{\text{LOAD}}$  (ESR), where ESR is the effective series resistance of  $C_{\text{OUT}}$ .  $\Delta I_{\text{LOAD}}$  also begins to charge or discharge  $C_{\text{OUT}}$  generating the feedback error signal that forces the regulator to adapt to the current change and return  $V_{\text{OUT}}$  to its steady-state value. During this recovery time  $V_{\text{OUT}}$  can be monitored for excessive overshoot or ringing, which would indicate a stability problem. OPTI-LOOP compensation allows the transient response to be optimized over a wide range of output capacitance and ESR values. *The availability of the  $I_{\text{TH}}$  pin not only allows optimization of control loop behavior, but it also provides a DC coupled and AC filtered closed-loop response test point. The DC step, rise time and settling at this test point truly reflects the closed-loop response.* Assuming a predominantly second order system, phase margin and/or damping factor can be estimated using the percentage of overshoot seen at this pin. The bandwidth can also

be estimated by examining the rise time at the pin. The  $I_{\text{TH}}$  external components shown in Figure 13 circuit will provide an adequate starting point for most applications.

The  $I_{\text{TH}}$  series  $R_{\text{C}}\text{-}C_{\text{C}}$  filter sets the dominant pole-zero loop compensation. The values can be modified slightly (from 0.5 to 2 times their suggested values) to optimize transient response once the final PC layout is done and the particular output capacitor type and value have been determined. The output capacitors need to be selected because the various types and values determine the loop gain and phase. An output current pulse of 20% to 80% of full-load current having a rise time of 1 $\mu\text{s}$  to 10 $\mu\text{s}$  will produce output voltage and  $I_{\text{TH}}$  pin waveforms that will give a sense of the overall loop stability without breaking the feedback loop.

Placing a resistive load and a power MOSFET directly across the output capacitor and driving the gate with an appropriate signal generator is a practical way to produce a realistic load step condition. The initial output voltage step resulting from the step change in output current may not be within the bandwidth of the feedback loop, so this signal cannot be used to determine phase margin. This is why it is better to look at the  $I_{\text{TH}}$  pin signal which is in the feedback loop and is the filtered and compensated control loop response.

The gain of the loop will be increased by increasing  $R_{\text{C}}$  and the bandwidth of the loop will be increased by decreasing  $C_{\text{C}}$ . If  $R_{\text{C}}$  is increased by the same factor that  $C_{\text{C}}$  is decreased, the zero frequency will be kept the same, thereby keeping the phase shift the same in the most critical frequency range of the feedback loop. The output voltage settling behavior is related to the stability of the closed-loop system and will demonstrate the actual overall supply performance.

A second, more severe transient is caused by switching in loads with large (>1 $\mu\text{F}$ ) supply bypass capacitors. The discharged bypass capacitors are effectively put in parallel with  $C_{\text{OUT}}$ , causing a rapid drop in  $V_{\text{OUT}}$ . No regulator can alter its delivery of current quickly enough to prevent this sudden step change in output voltage if the load switch resistance is low and it is driven quickly. If the ratio of  $C_{\text{LOAD}}$  to  $C_{\text{OUT}}$  is greater than 1:50, the switch rise time

## APPLICATIONS INFORMATION

should be controlled so that the load rise time is limited to approximately  $25 \cdot C_{LOAD}$ . Thus a  $10\mu\text{F}$  capacitor would require a  $250\mu\text{s}$  rise time, limiting the charging current to about  $200\text{mA}$ .

### Design Example

As a design example for one channel, assume  $V_{IN} = 12\text{V}$  (nominal),  $V_{IN} = 22\text{V}$  (max),  $V_{OUT} = 3.3\text{V}$ ,  $I_{MAX} = 6\text{A}$ ,  $V_{SENSE(MAX)} = 50\text{mV}$  and  $f = 350\text{kHz}$ .

The inductance value is chosen first based on a 30% ripple current assumption. The highest value of ripple current occurs at the maximum input voltage. Tie the FREQ pin to GND, generating  $350\text{kHz}$  operation. The minimum inductance for 30% ripple current is:

$$\Delta I_{L(NOM)} = \frac{V_{OUT}}{f \cdot L} \left( 1 - \frac{V_{OUT}}{V_{IN(NOM)}} \right)$$

A  $3.9\mu\text{H}$  inductor will produce 29% ripple current. The peak inductor current will be the maximum DC value plus one half the ripple current, or  $6.88\text{A}$ . Increasing the ripple current will also help ensure that the minimum on-time of  $95\text{ns}$  is not violated. The minimum on-time occurs at maximum  $V_{IN}$ :

$$t_{ON(MIN)} = \frac{V_{OUT}}{V_{IN(MAX)} f} = \frac{3.3\text{V}}{22\text{V}(350\text{kHz})} = 429\text{ns}$$

The equivalent  $R_{SENSE}$  resistor value can be calculated by using the minimum value for the maximum current sense threshold ( $43\text{mV}$ ):

$$R_{SENSE} \leq \frac{43\text{mV}}{6.88\text{A}} = 0.006\Omega$$

Choosing 1% resistors:  $R_A = 25\text{k}$  and  $R_B = 80.6\text{k}$  yields an output voltage of  $3.33\text{V}$ .

The power dissipation on the topside MOSFET can be easily estimated. Choosing a Fairchild FDS6982S dual MOSFET results in:  $R_{DS(ON)} = 0.035\Omega/0.022\Omega$ ,  $C_{MILLER} = 215\text{pF}$ . At maximum input voltage with  $T(\text{estimated}) = 50^\circ\text{C}$ :

$$P_{MAIN} = \frac{3.3\text{V}}{22\text{V}} (6\text{A})^2 \left[ 1 + (0.005)(50^\circ\text{C} - 25^\circ\text{C}) \right] \\ (0.035\Omega) + (22\text{V})^2 \frac{6\text{A}}{2} (2.5\Omega)(215\text{pF}) \cdot \\ \left[ \frac{1}{5\text{V} - 2.3\text{V}} + \frac{1}{2.3\text{V}} \right] (350\text{kHz}) = 433\text{mW}$$

A short-circuit to ground will result in a folded back current of:

$$I_{SC} = \frac{25\text{mV}}{0.006\Omega} - \frac{1}{2} \left( \frac{95\text{ns}(22\text{V})}{3.9\mu\text{H}} \right) = 3.9\text{A}$$

with a typical value of  $R_{DS(ON)}$  and  $\delta = (0.005/^\circ\text{C})(25^\circ\text{C}) = 0.125$ . The resulting power dissipated in the bottom MOSFET is:

$$P_{SYNC} = (3.9\text{A})^2 (1.125)(0.022\Omega) = 376\text{mW}$$

which is less than under full-load conditions.

$C_{IN}$  is chosen for an RMS current rating of at least  $3\text{A}$  at temperature assuming only this channel is on.  $C_{OUT}$  is chosen with an ESR of  $0.02\Omega$  for low output ripple. The output ripple in continuous mode will be highest at the maximum input voltage. The output voltage ripple due to ESR is approximately:

$$V_{ORIPPLE} = R_{ESR} (\Delta I_L) = 0.02\Omega(1.75\text{A}) = 35\text{mV}_{P-P}$$

## APPLICATIONS INFORMATION

### PC Board Layout Checklist

When laying out the printed circuit board, the following checklist should be used to ensure proper operation of the IC. These items are also illustrated graphically in the layout diagram of Figure 11. Figure 12 illustrates the current waveforms present in the various branches of the 2-phase synchronous regulators operating in the continuous mode. Check the following in your layout:

1. Are the top N-channel MOSFETs MTOP1 and MTOP2 located within 1cm of each other with a common drain connection at  $C_{IN}$ ? Do not attempt to split the input decoupling for the two channels as it can cause a large resonant loop.
2. Are the signal and power grounds kept separate? The combined IC signal ground pin and the ground return of  $C_{INTV_{CC}}$  must return to the combined  $C_{OUT}$  (-) terminals. The path formed by the top N-channel MOSFET, Schottky diode and the  $C_{IN}$  capacitor should have short leads and PC trace lengths. The output capacitor (-) terminals should be connected as close as possible to the (-) terminals of the input capacitor by placing the capacitors next to each other and away from the Schottky loop described above.
3. Do the LTC3857-1  $V_{FB}$  pins' resistive dividers connect to the (+) terminals of  $C_{OUT}$ ? The resistive divider must be connected between the (+) terminal of  $C_{OUT}$  and signal ground. The feedback resistor connections should not be along the high current input feeds from the input capacitor(s).
4. Are the  $SENSE^-$  and  $SENSE^+$  leads routed together with minimum PC trace spacing? The filter capacitor between  $SENSE^+$  and  $SENSE^-$  should be as close as possible to the IC. Ensure accurate current sensing with Kelvin connections at the  $SENSE$  resistor.
5. Is the  $INTV_{CC}$  decoupling capacitor connected close to the IC, between the  $INTV_{CC}$  and the power ground pins? This capacitor carries the MOSFET drivers' current peaks. An additional  $1\mu F$  ceramic capacitor placed immediately next to the  $INTV_{CC}$  and PGND pins can help improve noise performance substantially.
6. Keep the switching nodes (SW1, SW2), top gate nodes (TG1, TG2), and boost nodes (BOOST1, BOOST2) away from sensitive small-signal nodes, especially from the opposites channel's voltage and current sensing feedback pins. All of these nodes have very large and fast moving signals and therefore should be kept on the *output side* of the LTC3857-1 and occupy minimum PC trace area.
7. Use a modified *star ground* technique: a low impedance, large copper area central grounding point on the same side of the PC board as the input and output capacitors with tie-ins for the bottom of the  $INTV_{CC}$  decoupling capacitor, the bottom of the voltage feedback resistive divider and the SGND pin of the IC.

### PC Board Layout Debugging

Start with one controller on at a time. It is helpful to use a DC-50MHz current probe to monitor the current in the inductor while testing the circuit. Monitor the output switching node (SW pin) to synchronize the oscilloscope to the internal oscillator and probe the actual output voltage as well. Check for proper performance over the operating voltage and current range expected in the application. The frequency of operation should be maintained over the input voltage range down to dropout and until the output load drops below the low current operation threshold—typically 15% of the maximum designed current level in Burst Mode operation.

The duty cycle percentage should be maintained from cycle to cycle in a well-designed, low noise PCB implementation. Variation in the duty cycle at a subharmonic rate can suggest noise pickup at the current or voltage sensing inputs or inadequate loop compensation. Overcompensation of the loop can be used to tame a poor PC layout if regulator bandwidth optimization is not required. Only after each controller is checked for its individual performance should both controllers be turned on at the same time. A particularly difficult region of operation is when one controller channel is nearing its current comparator trip point when the other channel is turning on its top MOSFET. This occurs around 50% duty cycle on either channel due to the phasing of the internal clocks and may cause minor duty cycle jitter.

APPLICATIONS INFORMATION

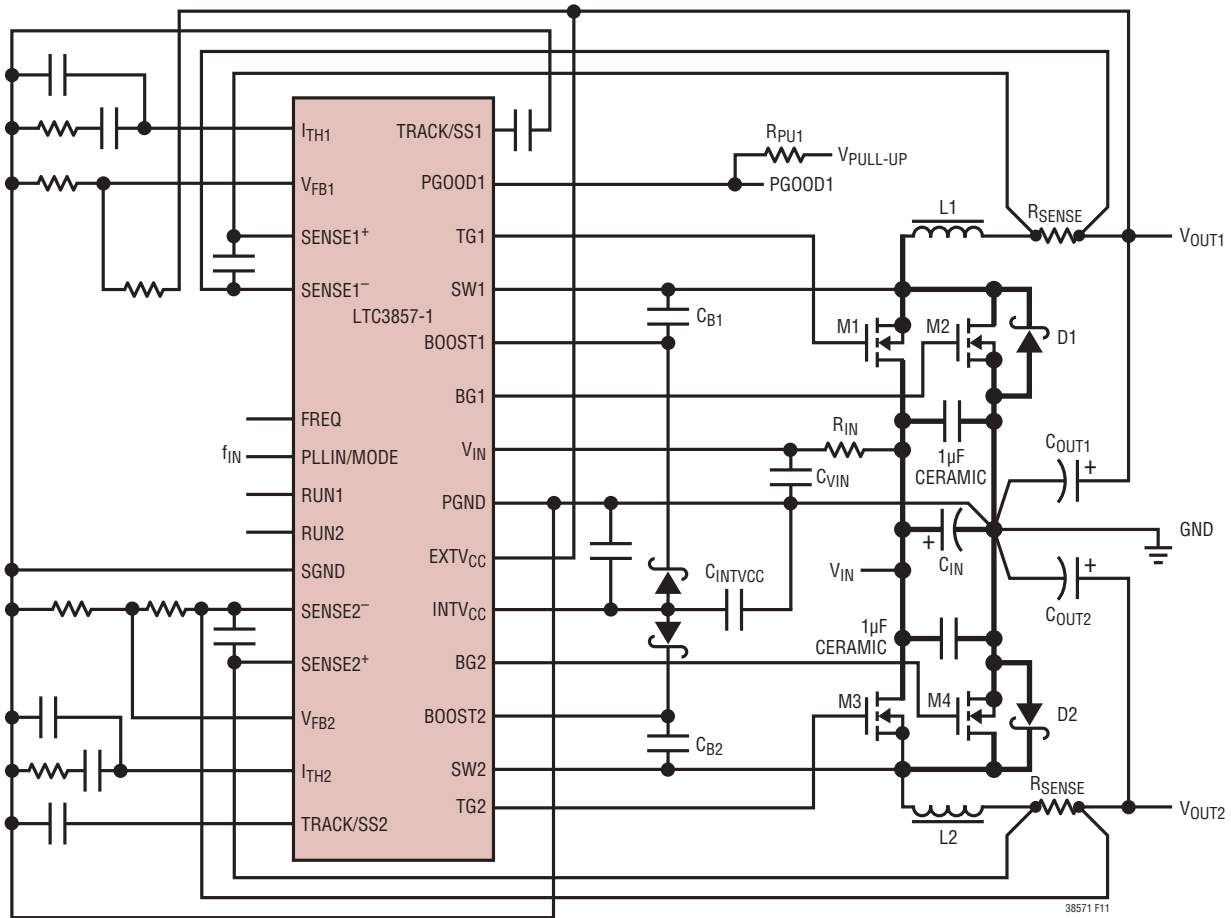

Figure 11. Recommended Printed Circuit Layout Diagram

Reduce  $V_{IN}$  from its nominal level to verify operation of the regulator in dropout. Check the operation of the undervoltage lockout circuit by further lowering  $V_{IN}$  while monitoring the outputs to verify operation.

Investigate whether any problems exist only at higher output currents or only at higher input voltages. If problems coincide with high input voltages and low output currents, look for capacitive coupling between the BOOST, SW, TG,

and possibly BG connections and the sensitive voltage and current pins. The capacitor placed across the current sensing pins needs to be placed immediately adjacent to the pins of the IC. This capacitor helps to minimize the effects of differential noise injection due to high frequency capacitive coupling. If problems are encountered with high current output loading at lower input voltages, look for inductive coupling between  $C_{IN}$ , Schottky and the top

## APPLICATIONS INFORMATION

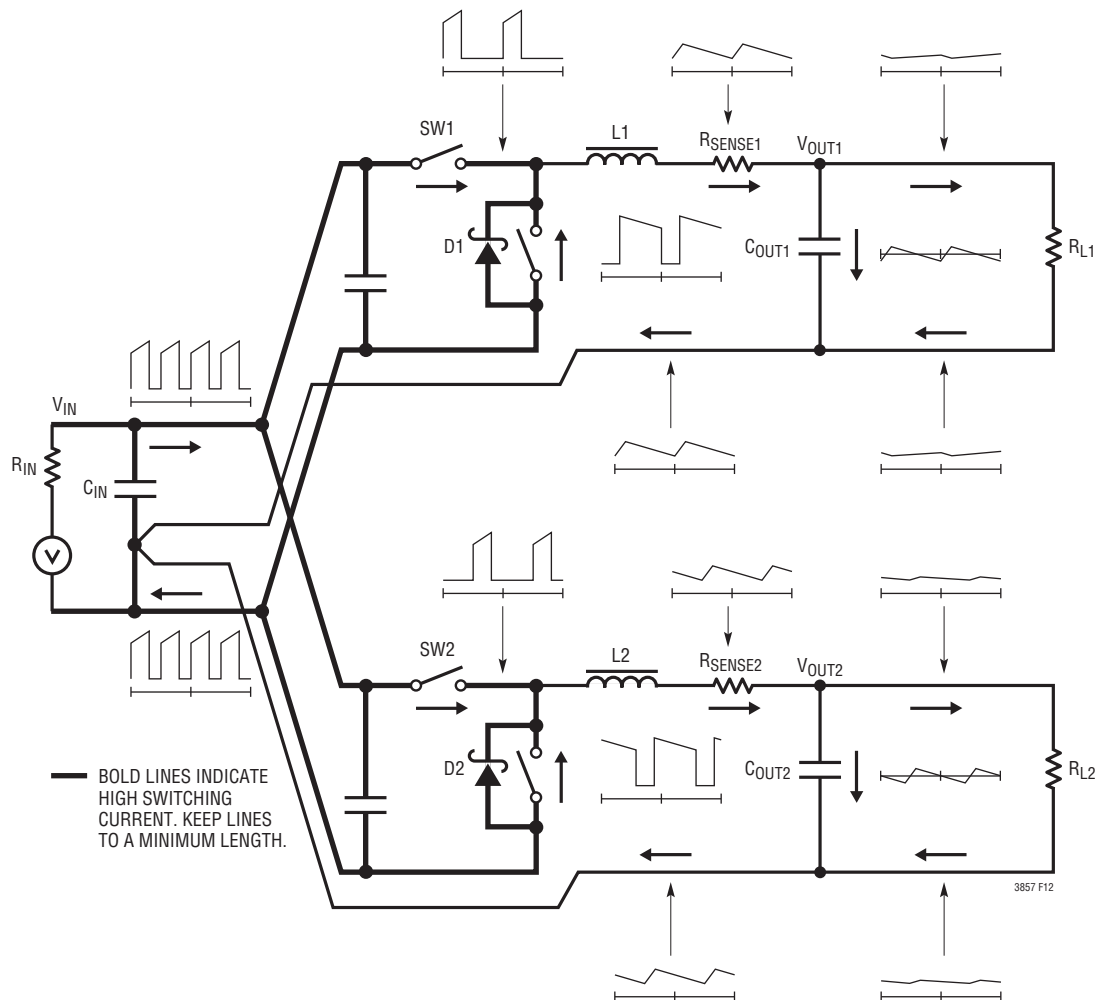

Figure 12. Branch Current Waveforms

MOSFET components to the sensitive current and voltage sensing traces. In addition, investigate common ground path voltage pickup between these components and the SGND pin of the IC.

An embarrassing problem, which can be missed in an otherwise properly working switching regulator, results when the current sensing leads are hooked up backwards.

The output voltage under this improper hookup will still be maintained but the advantages of current mode control will not be realized. Compensation of the voltage loop will be much more sensitive to component selection. This behavior can be investigated by temporarily shorting out the current sensing resistor—don't worry, the regulator will still maintain control of the output voltage.

## TYPICAL APPLICATIONS

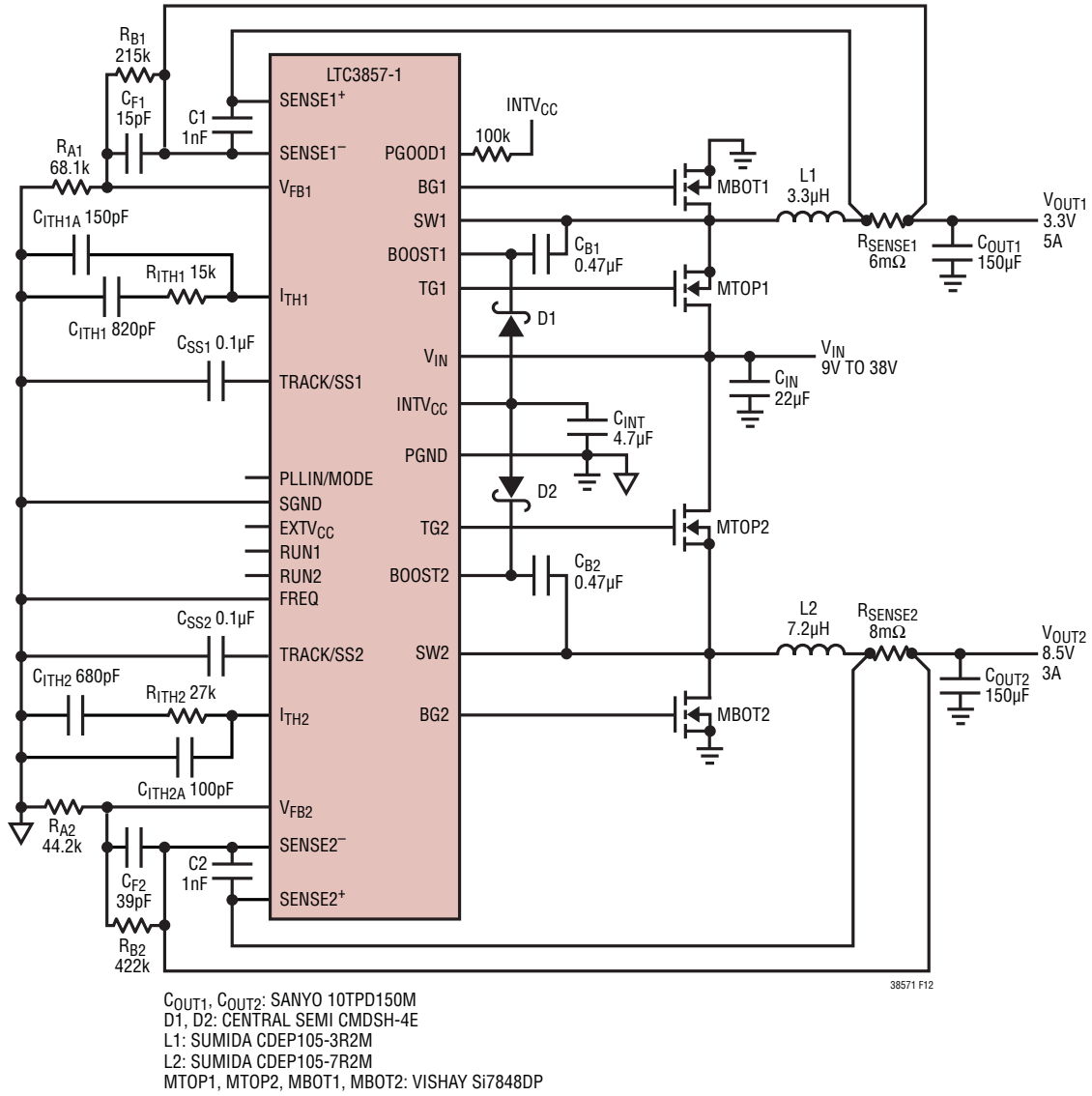
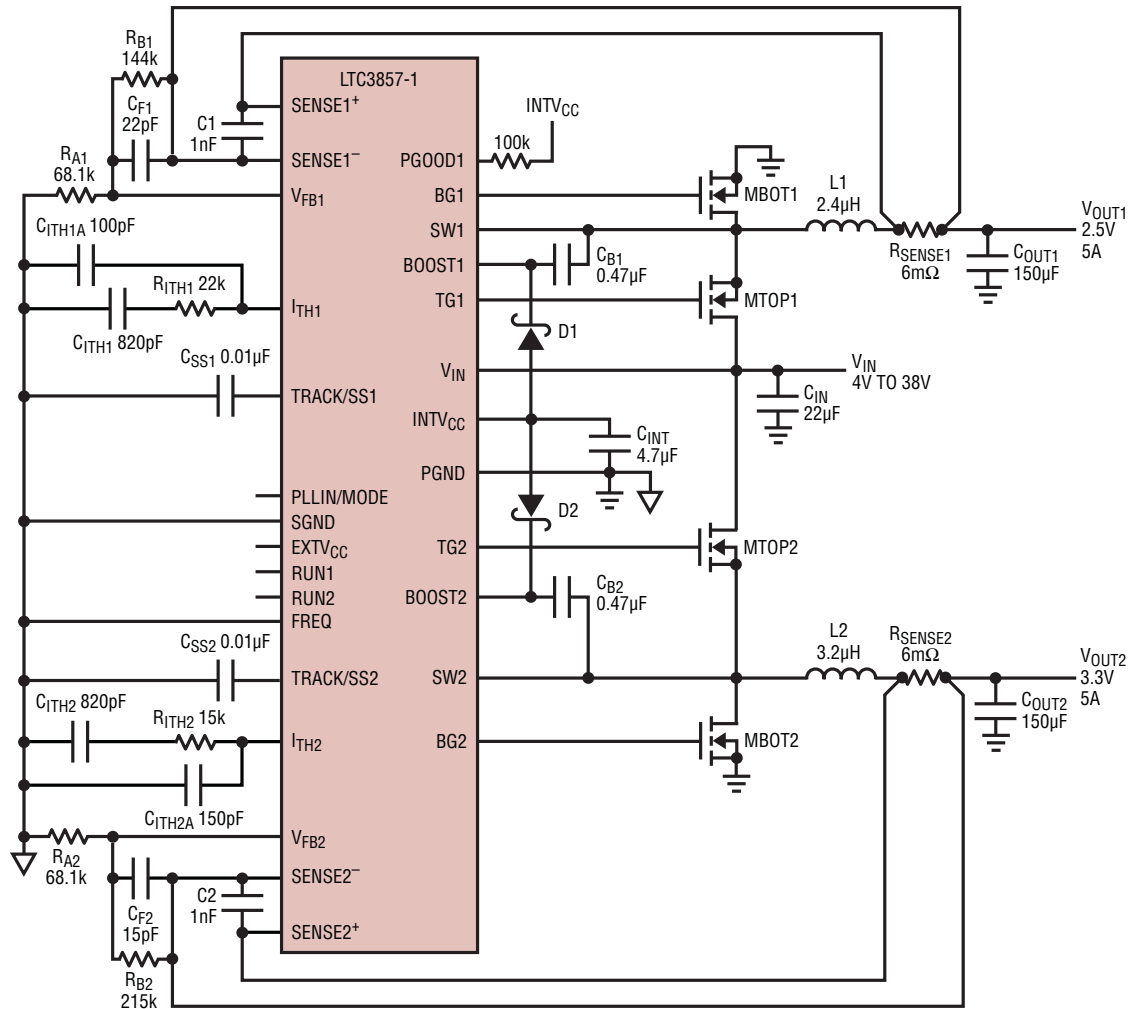

Figure 13. High Efficiency Dual 3.3V/8.5V Step-Down Converter

# TYPICAL APPLICATIONS

## High Efficiency Dual 2.5V/3.3V Step-Down Converter



C<sub>OUT1</sub>, C<sub>OUT2</sub>: SANYO 4TPE150M  
 D1, D2: CENTRAL SEMI CMDSH-4E  
 L1: SUMIDA CDEP105-2R5  
 L2: SUMIDA CDEP105-3R2M  
 M<sub>TOP1</sub>, M<sub>TOP2</sub>, M<sub>BOT1</sub>, M<sub>BOT2</sub>: VISHAY Si7848DP

38571 TA02

TYPICAL APPLICATIONS

High Efficiency Dual 12V/5V Step-Down Converter

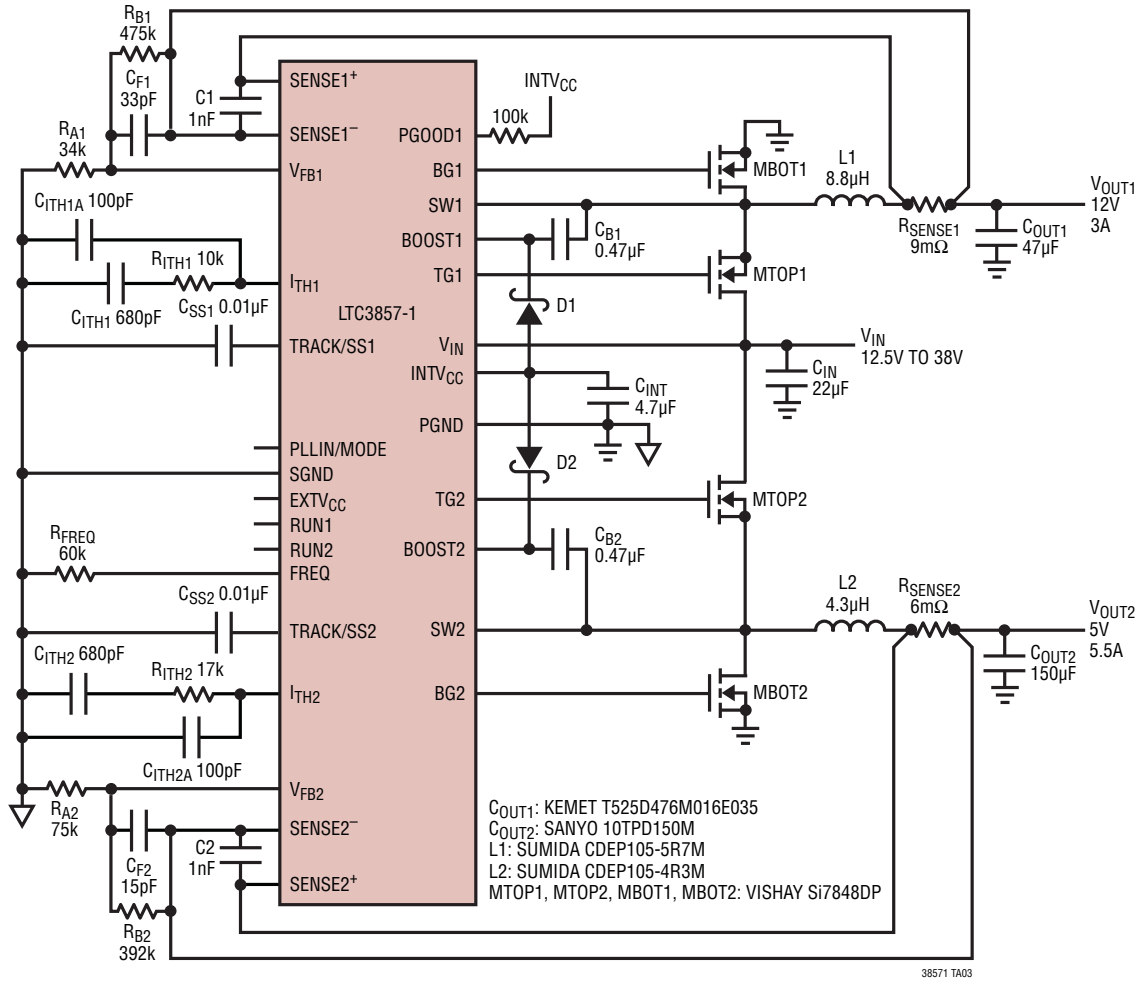

38571 TA03

# TYPICAL APPLICATIONS

## High Efficiency Dual 24V/5V Step-Down Converter

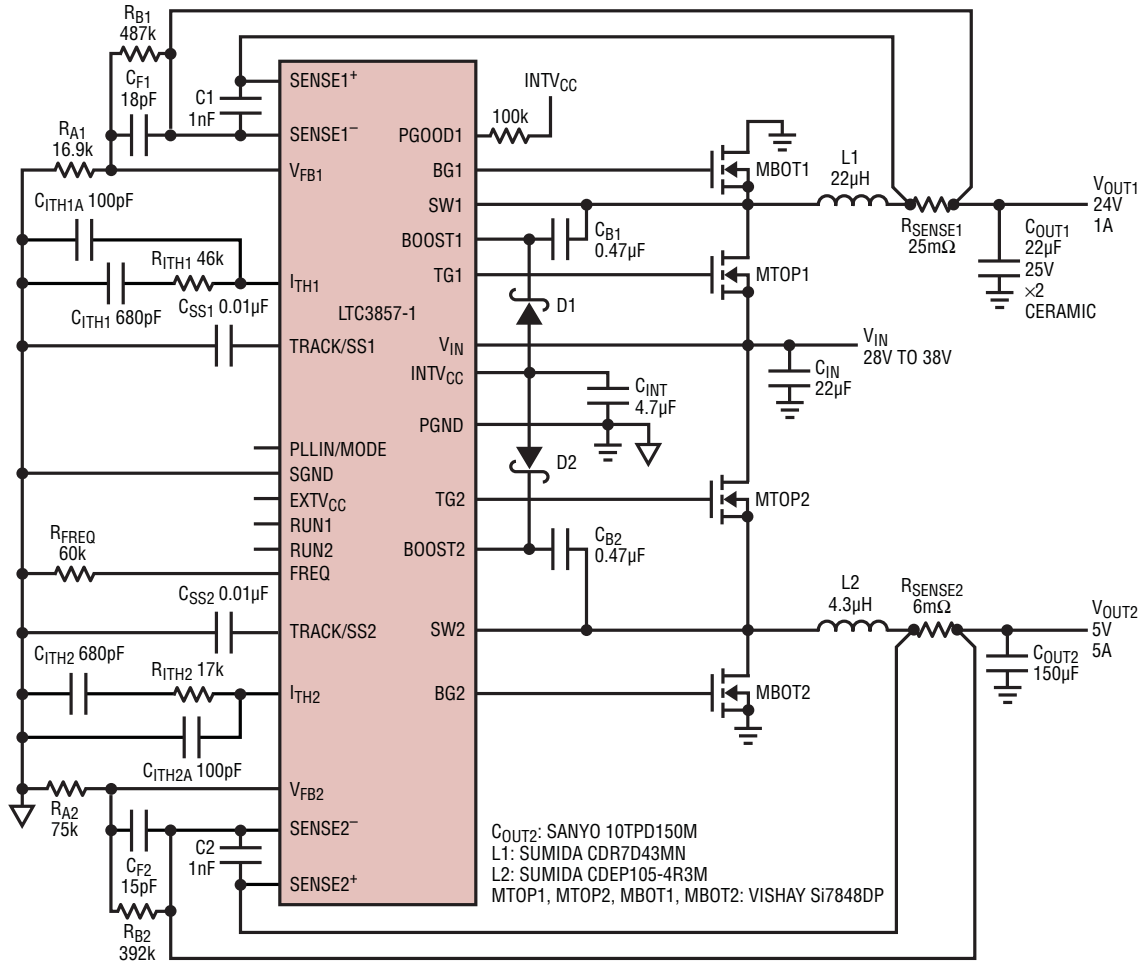

38571 TA04

TYPICAL APPLICATIONS

High Efficiency Dual 1V/1.2V Step-Down Converter

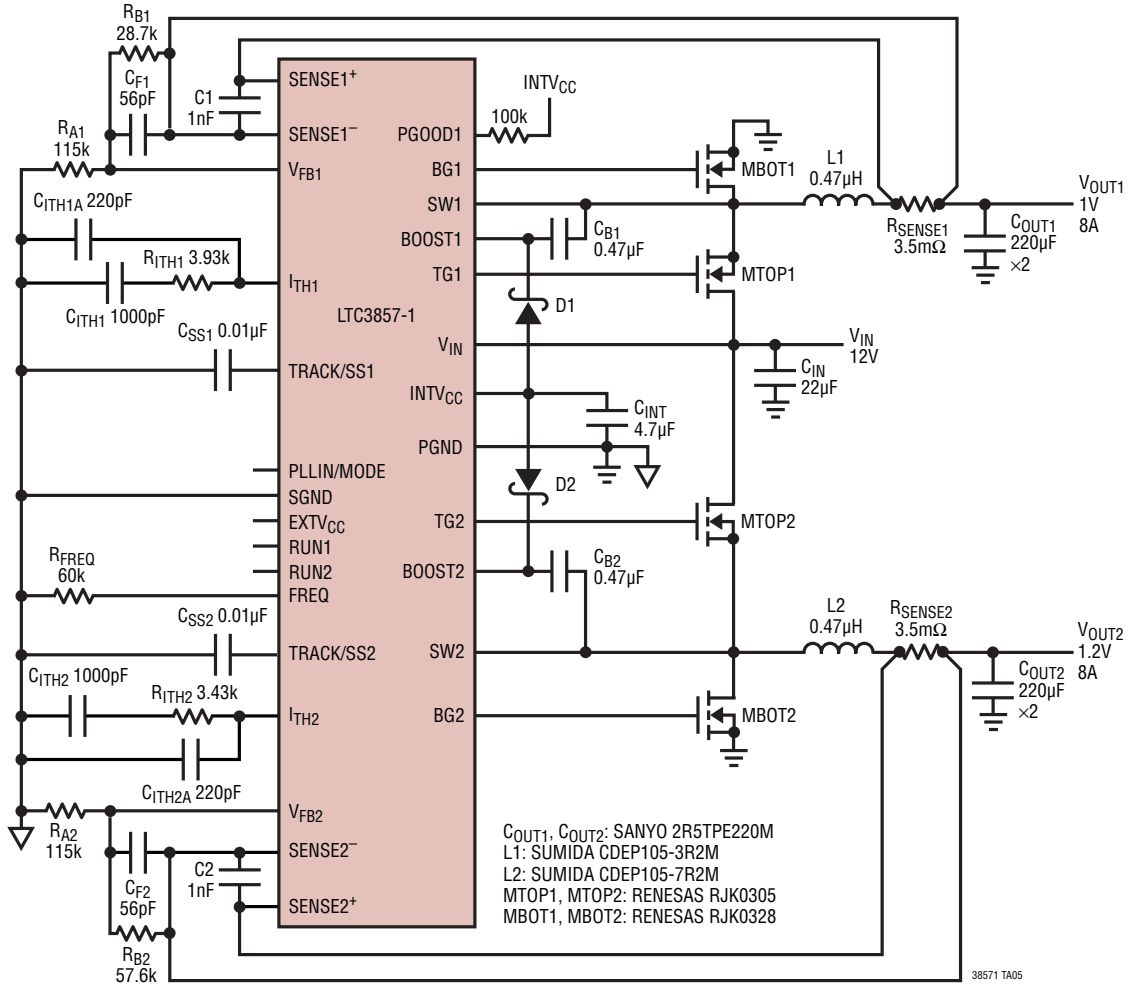

# TYPICAL APPLICATIONS

## High Efficiency Dual 1V/1.2V Step-Down Converter with Inductor DCR Current Sensing

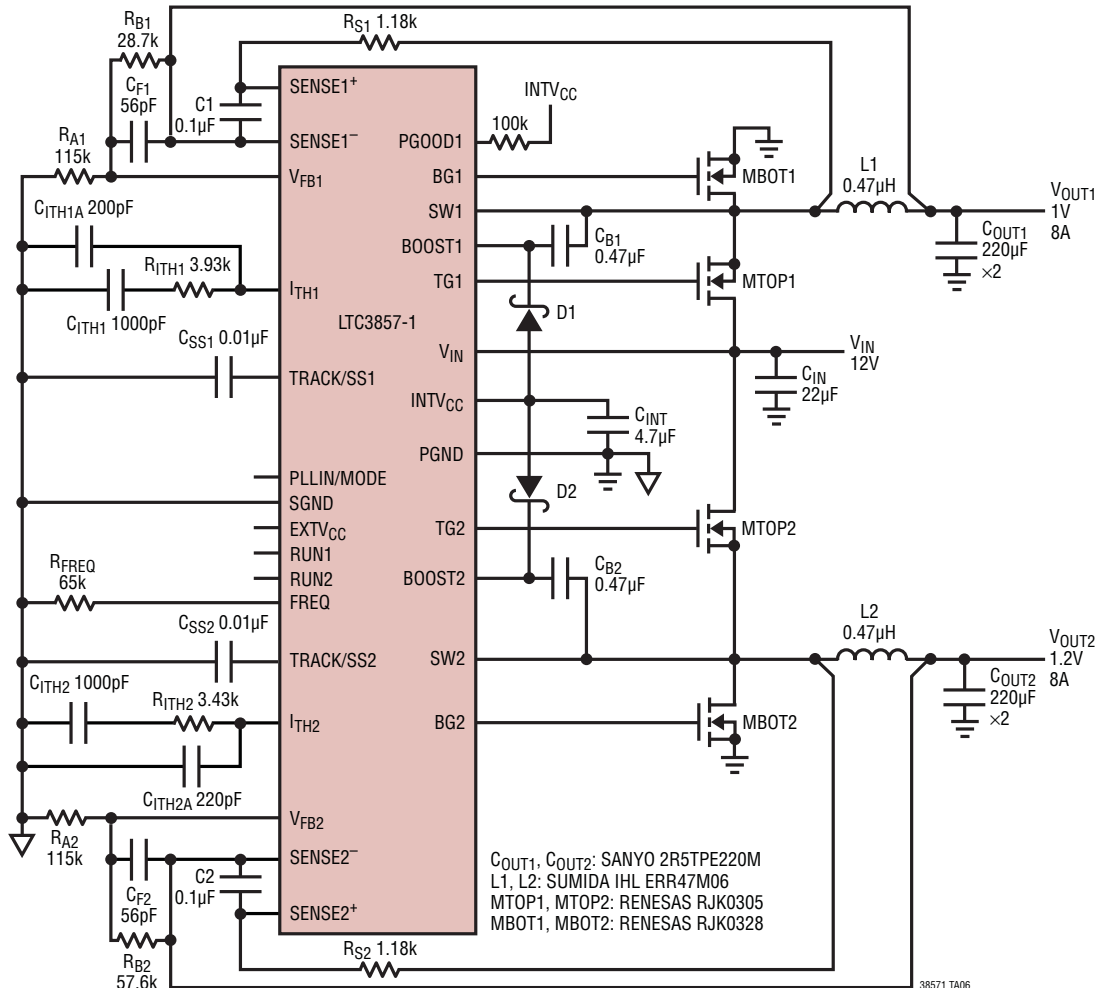

## PACKAGE DESCRIPTION

Please refer to <http://www.linear.com/designtools/packaging/> for the most recent package drawings.

### GN Package 28-Lead Plastic SSOP (Narrow .150 Inch) (Reference LTC DWG # 05-08-1641)

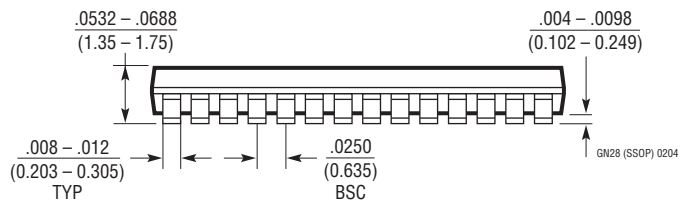
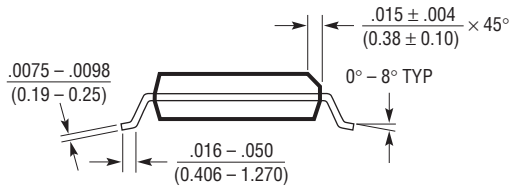
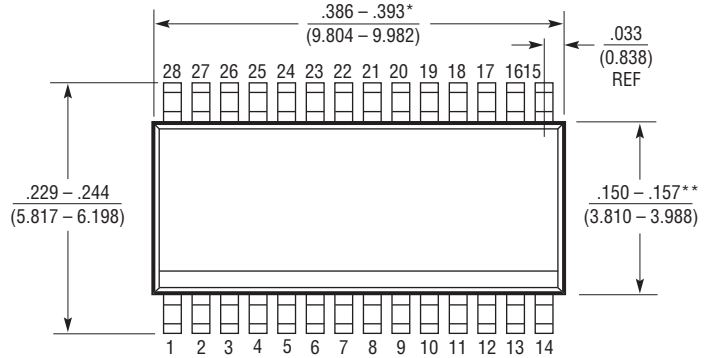
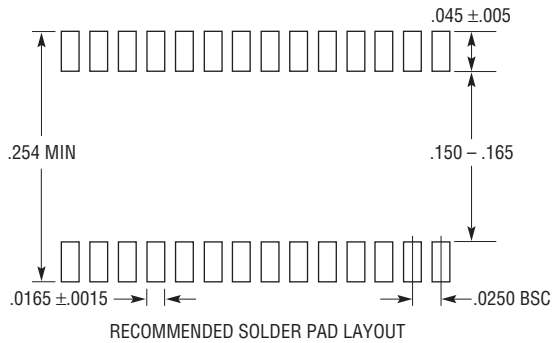

**NOTE:**

1. CONTROLLING DIMENSION: INCHES
2. DIMENSIONS ARE IN  $\frac{\text{INCHES}}{\text{(MILLIMETERS)}}$
3. DRAWING NOT TO SCALE

\*DIMENSION DOES NOT INCLUDE MOLD FLASH. MOLD FLASH SHALL NOT EXCEED 0.006" (0.152mm) PER SIDE

\*\*DIMENSION DOES NOT INCLUDE INTERLEAD FLASH. INTERLEAD FLASH SHALL NOT EXCEED 0.010" (0.254mm) PER SIDE

## REVISION HISTORY

REV	DATE	DESCRIPTION	PAGE NUMBER
A	12/09	Change to Absolute Maximum Ratings	2
		Changes to Electrical Characteristics	3, 4
		Change to Typical Performance Characteristics	6
		Change to Pin Functions	8, 9
		Text Changes to Operation Section	11, 12, 13
		Text Changes to Applications Information Section	21, 22, 23, 26
		Change to Table 2	23
		Change to Figure 11	28
		Changes to Related Parts	38
B	12/10	Change to Electrical Characteristics	3, 4
		Change to Graph G07	5
		Added Typical Application to back page and updated Related Parts	38
C	01/12	Added $V_{FB}$ conditions for $I_Q$ specification	3
		Changed $V_{FB}$ to $V_{FB1}$ in conditions for $V_{PG}$ specification	4
		Changed 80 $\mu$ A to 65 $\mu$ A in the Light Load Current Operation section	12
		Changed 24V to 28V in SENSE <sup>+</sup> and SENSE <sup>-</sup> Pins section	15

## TYPICAL APPLICATION

### High Efficiency 2-Phase 12V/150W Step-Down Converter

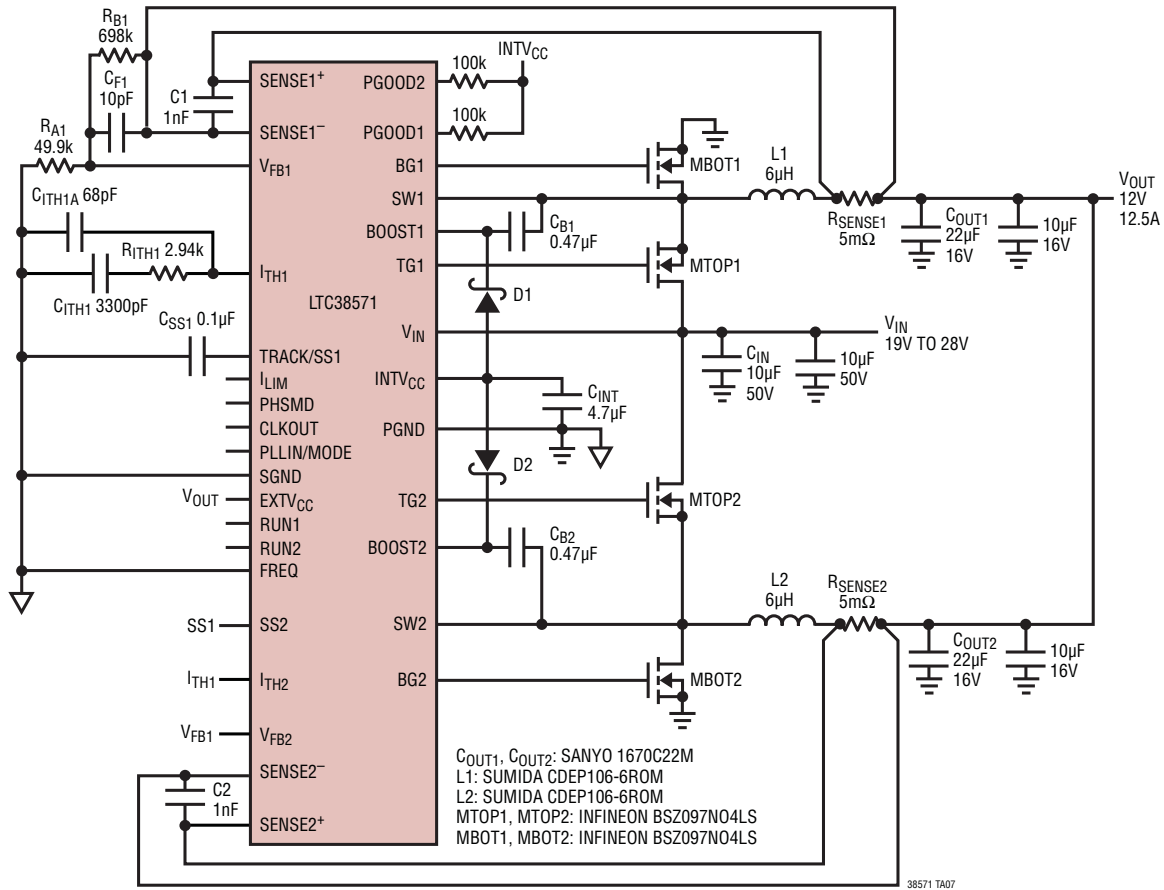

## RELATED PARTS

PART NUMBER	DESCRIPTION	COMMENTS
LTC3859	Low $I_Q$ , Triple Output Buck/Buck-Boost Synchronous DC/DC Controller	Outputs ( $\geq 5V$ ) Remain in Regulation Through Cold Crank, $2.5V \leq V_{IN} \leq 38V$ , $V_{OUT(BUCK)}$ Up to 24V, $V_{OUT(BOOST)}$ Up to 60V, $I_Q = 55\mu A$ ,
LTC3868/LTC3868-1	Low $I_Q$ , Dual Output 2-Phase Synchronous Step-Down DC/DC Controller with 99% Duty Cycle	Phase-Lockable Fixed Operating Frequency 50kHz to 900kHz, $4V \leq V_{IN} \leq 24V$ , $0.8V \leq V_{OUT} \leq 14V$ , $I_Q = 170\mu A$ ,
LTC3858/LTC3858-1	Low $I_Q$ , Dual Output 2-Phase Synchronous Step-Down DC/DC Controller with 99% Duty Cycle	Phase-Lockable Fixed Operating Frequency 50kHz to 900kHz, $4V \leq V_{IN} \leq 38V$ , $0.8V \leq V_{OUT} \leq 24V$ , $I_Q = 170\mu A$ ,
LTC3890/LTC3890-1	60V, Low $I_Q$ , Dual 2-Phase Synchronous Step-Down DC/DC Controller with 99% Duty Cycle	Phase-Lockable Fixed Operating Frequency 50kHz to 900kHz, $4V \leq V_{IN} \leq 60V$ , $0.8V \leq V_{OUT} \leq 24V$ , $I_Q = 50\mu A$ ,
LTC3834/LTC3834-1	Low $I_Q$ , Synchronous Step-Down DC/DC Controller	Phase-Lockable Fixed Operating Frequency 140kHz to 650kHz, $4V \leq V_{IN} \leq 36V$ , $0.8V \leq V_{OUT} \leq 10V$ , $I_Q = 30\mu A$ ,
LTC3835/LTC3835-1	Low $I_Q$ , Synchronous Step-Down DC/DC Controller	Phase-Lockable Fixed Operating Frequency 140kHz to 650kHz, $4V \leq V_{IN} \leq 36V$ , $0.8V \leq V_{OUT} \leq 10V$ , $I_Q = 80\mu A$ ,
LT3845	Low $I_Q$ , High Voltage Synchronous Step-Down DC/DC Controller	Adjustable Fixed Operating Frequency 100kHz to 500kHz, $4V \leq V_{IN} \leq 60V$ , $1.23V \leq V_{OUT} \leq 36V$ , $I_Q = 120\mu A$ , TSSOP-16
LTC3824	Low $I_Q$ , High Voltage DC/DC Controller, 100% Duty Cycle	Selectable Fixed 200kHz to 600kHz Operating Frequency, $4V \leq V_{IN} \leq 60V$ , $0.8V \leq V_{OUT} \leq V_{IN}$ , $I_Q = 40\mu A$ , MSOP-10E

38571fc